

## UNIT-1: INTRODUCTION AND SCOPE OF MICROBIOLOGY

### Introduction

Microbiology is the science that deals with the study of microorganisms. The term microbiology derives its name from three Greek words *mikros* [small] *bios* [life] and *logos* [study]. Microorganisms are tiny and invisible to naked eye. So, they can be looked into and studied only with the help of microscope.

Small subcellular or cellular living beings with milli-micron or micron in size and are not visible to our naked eyes are called micro-organisms.

Micro-organisms are basically classified under the following 2 groups:

1. **Prokaryotic microbes:** These include subcellular living entities like prions, viroid, viruses and cellular organisms like bacteria, cyanobacteria etc.
2. **Eukaryotic microbes:** These include cellular microbe belonging to following groups-
  - a. Algae. Ex: Chlamydomonas, Diatoms.
  - b. Fungi. Ex: Yeast, Rhizopus.
  - c. Protozoans. Ex: Plasmodium, Amoeba.

Micro-organisms are commonly called microbes and they were the first to occupy planet earth even before man and other creatures. Microbes are present in every part of biosphere.

### HISTORY OF MICROBIOLOGY

Although microbes were the first life forms to occupy the planet earth, the knowledge about microbiology is well developed with new dimension only after the invention of microscopes and contribution of knowledge to the field of microbiology from various scientists.

#### Contributions of Antony Van Leeuwenhoek

- He was Dutch Philosopher, born on 24 October 1632.
- He is regarded as Father of 'Bacteriology' and 'Protozoology', because of his contribution to the field of bacteria and protozoa.
- He invented simple microscope having magnification power up to 300X.
- He observed bacteria from his teeth scrap under the microscope invented by him and he named them as 'animalcules'.
- He also discovered bacteria in rain water ditch and protozoans like paramecium and amoeba.

- He presented all his observations with illustration before scientist organization 'Royal Society of London' in 1683.

### **Contributions of Louis Pasteur**

- He was a French Biochemist, born on 27 December 1822.
- He is regarded as 'Father of Microbiology and Immunology'.
- He proposed the 'Theory of Germ Disease', where diseases of plants, viruses, animals and human beings are caused by pathogenic microbes.
- He disproved the theory of abiogenesis by conducting 'Swan neck flask experiment'.
- He discovered the presence of bacteria in the air and classified the bacteria into aerobic and anaerobic forms.
- He coined the term 'microbiology', aerobic, anaerobic.
- He discovered the role of anaerobic microbes in the fermentation of sugar.
- He developed technique to prevent souring of milk and spoilage of wine. His technique is now called Pasteurization technique.
- He first isolated bacteria causing cholera (*Vibrio cholerae*).
- He developed technique to strengthen immunity against anthrax bacteria by injecting weakened anthrax bacteria to healthy animal.
- Pasteur demonstrated a disease of silkworm was due to a protozoan parasite.

### **Contributions of Robert Koch**

- He was a German microbiologist born on 11 December 1843.
- His contribution to the field of microbiology and medical science is the most valuable one.
- He developed for the first time culture technique to culture the bacteria in the laboratory.
- He discovered bacteria caused tuberculosis of man.
- He developed for the first time staining technique to stain the bacteria with acidic or basic stain.
- He isolated and identified different kinds of bacteria from various sample.
- He proved theory of germ diseases of Louis Pasteur by conducting investigative experiment.
- He was awarded Nobel Prize of medicine in 1905, formulating principles regarding diseases. These are now called 'Koch Postulates'.

Some of them are:-

- a. Specific pathogenic microbe causes one specific disease not more than one type of diseases in plants, animals and human beings.
- b. Specific pathogenic microbes can be isolate from diseased organism and cultured outside the diseased organism.

### **Contributions of Alexander Fleming**

- He was a Scotland doctor and biochemist born in 1881.
  - He contributed knowledge about antibiotic Penicillin for this kind of work.
  - He was awarded Nobel Prize in 1945.
- His contributions to the field of microbiology can be summarized as below.*
- He studied bacterial action in blood and their response to the antibiotic.
  - He worked on antimicrobial substances. That is not toxic to human body but toxic to microbial body.
  - He discovered bacteriolytic substance lysosome in the animal tissue.
  - He developed technic to study sensitivity of the microbes to the antibiotic drugs.

### **Scope of Microbiology as a Modern Science**

With the development of new laboratory techniques and experimental procedures our knowledge on characteristics on microbes accumulated rapidly.

Research on microbes gave booster for the recent developments in the genetic engineering and biotechnology scientists from many disciplines recognized the usefulness of microbes as experimental models Thus microbiology played a crucial role in the development of biotechnology. Microbes like *E.coli* facilitated in biotechnology.

The gene cloning in the industrial production of some therapeutics such as insulin, interleukin, calcitonin etc. The molecular scissors (Restriction endonucleases) that used in genetic engineering are isolated from the microbial sources.

The plasmids (small circular extra chromosomal self-replicating DNA) derived from microbes are used as vectors for transferring genes form one organism to another.

Ex: PUC<sub>18</sub>, PBR<sub>322</sub>, etc.

The bacterium like *Agrobacterium tumefaciens* can be employed to generate transgenic plants. This bacterium bears Ti (Tumour inducing) plasmids that can be used to transfer the desired genes in to host plant.

## Importance and Scope of Microbiology

Microbiology is an applied science that has great impact on genetics, biochemistry, food sciences, ecology, immunology, agriculture, medicine and many other disciplines. Despite their small size they form the largest resource for biotechnology. Various microbial genera have been used to study their genetics and molecular biology.

"*Escherichia Coli*" is a wonderful colon bacterium that has been extensively studied by biotechnologists. They used it for cloning and Microbes play a pivotal role in human welfare majority of the microbes are useful to mankind but some of them are harmful as they cause infectious diseases in human beings, domestic animals and agricultural crops.

### 1. Biotechnology:

- a. Microbes produce very important DNA manipulating enzymes like REN (Restriction Endo Nucleases) and Ligase. These two are used as molecular scissors and stitches in biotechnology/ Genetic Engineering.
- b. Some microbes, for example: *E.coli* is used as host organism to clone desired gene for desired product.

### 2. Agriculture: from the point of agriculture microbes play an important role in the following aspects.

- a. Some microbes can be used as bio-fertilizers to enrich soil fertility.
- b. Some bacteria can fix inert atmospheric nitrogen known as nitrogen fixing bacteria. Ex: rhizobium, Azotobacter, Anabaena etc.
- c. Some microbes like viruses and bacteria are used as bio-pesticides to protect the crop plants from pest and insect eating.

### 3. Industry: from the point of industry, microbes are extremely useful

- a. for the production of industrial chemicals like acetic acid, lactic acid, citric acid etc. by fermentation process.
- b. Microbes also find their importance in food industry and dairy industries to produce fermented food products.
- c. Microbes also play an important role in the production of ethyl alcohol in brewing industry.
- d. Microbes also find their importance in food and dairy industry to produce fermented food products.

**4. Medicine:**

- a. From the point of medicine various kinds of antibiotics used to treat pathogenic diseases of man and animals are derived from microbial group called actinomycetes.
- b. Some heat killed microbes are used as vaccine against various kinds of pathogenic microbes causing diseases.

**5. Environment:**

- a. Microbes help to clean the environment by degrading all kinds of biodegradable waste products. Hence, the microbes are regarded as scavengers of nature.
- b. Microbes play important role bio-geo chemical cycles.
- c. Microbes also play an important role in the production of Bio-gas from the biological waste products.

**6. Bio-remediation:** Is a method of pollution alleviation using microbes. Several bacteria and fungi are capable of decay the natural waste, toxic chemicals, heavy metals, oil spills etc.

**7. Bioleaching:** When the ore contains lower metal content, it is difficult to extract them by direct smelting, in such cases some microbes (*Thiobacillus* species) are used to separate the mineral from crude ores. This process is known as bioleaching or microbial leaching.

**BRANCHES OF MICROBIOLOGY**

With the accumulation of knowledge about various aspects of microbes since the last century and has spread in to various branches. Thus the various aspects of microbiology study can be divided basically in to following branches.

**1. Industrial Microbiology**

It deals with the exploitation of microbes for industrial production. Here the microbes can be considered as mini chemical factories, as they are capable of converting some raw materials into end products which have value for human use.

Microbes have been used to produce alcohols, antibiotics and organic acids, in industrial scale. The study of fermentation by microorganisms has provided booster to beverage industry.

Recently with great advances in recombinant DNA technologies, provided a better route to manipulate microbes genetically to produce new products.

## **2. Dairy Microbiology**

It deals with the study of harmful and beneficial bacteria present in milk and milk products. In dairy microbiology the aspects like production of (yogurt) fermented milk products. Pasteurization of milk and milk products can be studied. Many such fermented milk products are used in treatment of dysentery and gastro enteritis.

## **3. Environmental Microbiology**

It is one of the important branches of microbiology where the role of microbes in maintaining quality of environment is studied. Since microbes are found in every environment the air, water, soil and food, they influence the degradation and decay of natural wastes (bioremediation) they also influence the energy flow in ecosystem.

The study also helps to understand freshwater and marine water and their microbes. Recently it has been shown that some genetically modified microbes can help in cleaning oil spills and this gives an added advantage to the study of environmental microbiology.

## **4. Food Microbiology**

It is concerned with study of role of microbes in food processing, food preservation and canning. Extensive study of microbes in relation to food products lead to characterization of microbes.

As a result new methods have developed and old methods have been improved. This branch also provides a platform for the study of food borne microbial diseases and their control.

## **5. Agricultural Microbiology**

In this branch, the role of microbial activity in plants and their surroundings is studied. Many microbes like fungi, bacteria, and viruses cause many diseases in plants.

This branch is concerned with study of nitrogen fixation activity. Use of microbes as bio-fertilizers, use of microbes as bio pesticides and many more aspects.

## **6. Medical Microbiology**

The study of pathogenic microbes, the etiology, their life cycle, physiology. Genetics, pathogenicity and control are known as medical microbiology. The integral part of medical microbiology is to understand how immune system of vertebrate protects themselves from pathogens and shows response to the pathogen.

This branch primarily allows the study of morphological and cultural characteristic resistance nature of microbes, their diagnosis, treatment and control of infectious diseases.

### **7. Air Microbiology**

The branch covers the study of dispersal of pathogenic microbes through air, microbial population in air and control of air borne microbes by chemical agents, radiations, filtration and laminar air flow methods.

### **8. Aquatic Microbiology**

It encompasses the study of microbes present in fresh water, ocean water and estuarine. This branch is of great significance that;

- Many aquatic microbes are pathogenic to human beings:
- Most of them are important in food chain in the ecosystem.
- They take part in recycling processes.
- They help in exploration of oils and minerals.

### **9. Immunology**

- It is one of the fastest growing areas that covers the practical health problems their nature and treatments.
- It is the study of immunity against invading microbes by a host.

### **10. Biotechnology**

- It is the most significant branch that deals with the application of biological techniques for the benefit of mankind.
- It encompasses the use of microbes for the production of drugs, fermented foods and treatment of waste.
- It also includes developing techniques for the more efficient production of specific compounds.
- It focuses on aspects such as nature of genetic material, regulation, development and function of a cell, the method of production of new microbial cells by recombinant DNA technology which are useful in industrial microbiology..

### **11. Exo-Microbiology**

This branch is still in its infancy, it includes explore and the study of microbes in outer space and other planets such as moon and mars.

## 12. Geo-chemical Microbiology

Study of role of microbes in coal, gas and mineral formation. Exploration of oil, gas and minerals is known as geochemical microbiology.

In addition to the above mentioned branches, the basic microbiology encompasses the following branches that are concerned with the study of morphology, ecology, taxonomy, genetics and physiology of specific groups of microbes.

1. Bacteriology-Study of bacteria
2. Phycology- Study of algae
3. Mycology -Study of fungi, [molds and yeasts].
4. Virology- Study of viruses
5. Protozoology- Study of protozoa

## FIVE KINGDOMS AND THE 3 DOMAIN CLASSIFICATIONS OF MICROORGANISMS

**Classification:** classification is a scheme by which various organisms are arranged according to the relationship between the individuals and groups.

In 1969, R. H. Whittaker proposed a five kingdom classification scheme that has been widely accepted universally. These five kingdoms are

- Monera
- Protista
- Fungi
- Plantae
- Animalia

Viruses are non-cellular molecular particles that remain on the threshold of life between living and non-living viruses are not included in any of these kingdoms and are treated as a separate group.

## FIVE KINGDOMS

### I. KINGDOM: MONERA (PROKARYOTA)

It includes two major groups namely bacteria and cyanobacteria blue green algae.

#### *Salient features of Monera*

- Monerans are present in both living and non-living environment.



- Some have rigid cell walls, while some do not.
- Membrane bound nucleus is absent in monerans.
- Habitat – Monerans are found everywhere in hot or thermal springs, in the deep ocean floor, under ice, in deserts and on or inside the body of plants and animals.
- They are autotrophic, i.e., they can synthesize food on their own while some others have a heterotrophic, saprophytic, parasitic, symbiotic, commensalistic and mutualistic modes of nutrition.
- Locomotion is with the help of flagella.
- Circulation is through diffusion.
- Respiration in these organisms vary, few are obligate aerobes, while some are obligate anaerobes and facultative anaerobes
- Reproduction is mostly asexual and few also reproduce by sexual reproduction.
- Usually the cells undergo reproduction by budding or binary fission.
- Examples: *Mycobacterium*, *E.coli*, *Streptococcus* etc.

## II. Kingdom Protista

The term 'Protista' is derived from the Greek word "*Protistos*", meaning "*the very first*".

These organisms are usually unicellular and the cells of these organisms contain a nucleus which is bound to the organelles. Some of them even possess structures that aid locomotion like flagella or cilia.

### *Salient features*

- They are simple, unicellular, eukaryotic organisms.
- Most of the protists live in water, some in moist soil or even the body of human and plants.
- These organisms have a membrane-bound nucleus, endomembrane systems, mitochondria for cellular respiration and some have chloroplasts for photosynthesis.
- Nuclei contain multiple DNA strands and the number of nucleotides is significantly less.
- Respiration – cellular respiration is the primarily aerobic process, but some living in the moist soil underneath ponds or in digestive tracts of animals are facultative anaerobes.
- Locomotion is often by flagella or cilia.
- Nutrition- include both heterotrophic and autotrophic.

- Reproduction – Some reproduce sexually and others asexually.
- Some protists are pathogens of both plants and animals. Example: Plasmodium falciparum causes malaria in humans.
- Examples: *Amoeba*, *Paramecium*, *Euglena*.

### **Kingdom Mycota (Fungi)**

These include yeast and molds. These are non-photosynthetic heterotrophs having either parasitic or saprophytic mode of nutrition.

*General features of fungi are as follows:*

- Fungi are eukaryotic, non-vascular and non-motile organisms.
- The growth rate of fungi is slower than that of bacteria.
- The Kingdom Fungi grow best in an acidic environment.
- The Kingdom Fungi consist of both unicellular (e.g. Yeast, Molds) and multicellular (e.g. mushrooms) organisms.
- Like plant cells, fungi have cell walls made up of complex sugar molecules called chitin. But unlike plants, they do not undergo photosynthesis.
- The vegetative body of the fungi may be unicellular or composed of microscopic threads called hyphae.
- They have a heterotrophic mode of nutrition. Few species are saprophytes i.e., they feed on dead and decaying organic matters.
- Some fungi are parasitic while some are symbionts.
- Reproduction in fungi is both by sexual and asexual means.
- Examples: *Mycorrhiza*, *Saccharomyces* etc.

### **Kingdom Plantae**

- Plants are multicellular organisms compared of eukaryotic cells.
- The cells are organized into tissues and have cell wall.
- They obtain nutrients by photosynthesis and absorption.
- They are primarily non-motile and live anchored to a substance.
- Reproduction is sexual and asexual.
- Ex: mosses, ferns, conifers and flowering plants.

**Kingdom Animalia**

- Animals are multicellular organisms composed of eukaryotic cells.
- The cells are organized into tissue and lack cell wall.
- They do not carry out photosynthesis and obtain nutrients primarily by ingestion.
- Many animals are adapted for locomotion.
- Heterotrophic mode of nutrition.
- They reproduce by sexual mode of reproduction.
- Ex: sponges, worms, insects and vertebrates.

**THREE DOMAIN CLASSIFICATIONS**

This system was proposed by *Carl Woese* in 1978 on the basis of molecular biology and biochemistry. This classification is entirely dependent on the differences in the nucleotide sequences of rRNA in the cells and also differences in cell membrane lipids structure. The sequence similarity in the rRNA molecule provided a strong basement to predict the evolutionary classification of microbes.

According to this classification system and ancestor cell give rise to three different cell types. Each representing a domain viz; Archaea, the Bacteria (prokaryotes) and Eukarya (eukaryotes) which includes algae, fungi Protozoa, plants and animals.

**I. The Archaea (archaebacteria)**

Archaea bacteria represent a unique group of microorganisms that are related to bacteria, but might have deviated from the evolutionary live of bacteria very early during the evolution of Monera. They are considered as the primitive bacteria.

*Salient features of Archaea*

1. The cell wall lack (peptidoglycan) (psedopeptidoglycan).
2. The membrane consist of characteristic lipids i.e. the lipids have branched hydrocarbon that increase the fluidity of the membrane.

In some Archaea bacteria the plasma membrane is a monolayer composed of glycerol tetra ether lipids.

- The genome consists of single covalently closed circular DNA.

- Some of the Archaea bacteria can survive in extreme environment such as high temperature (Thermophiles) extremely halophilic (Salt Lakes, tidal pools) and anaerobic environments (methanogenic bacteria).
- The archaea are insensitive to certain antibiotics (ex: chloramphenicol) but are sensitive to diphtheria toxin.

## II. The Bacteria (eubacteria)

### *Salient features*

- They are unicellular prokaryotes.
- The bacterial cell wall contains peptidoglycan (murein).
- The cell membrane is composed of phospholipids.
- Bacteria are sensitive to some common antibiotics like tetracycline, ampicillin, and penicillin.
- The cytoplasm contains double stranded covalently closed circular DNA.
- Bacteria contain rRNA that is unique to the bacteria, as indicated by the presence of molecular region distinctly different from the rRNA of archaea and eukarya.
- Bacteria include mycoplasmas, cyanobacteria, gram positive and gram negative bacteria.

## III. The eukarya (eukaryotes)

The eukarya (also called as eukarya) possess the following characteristics.

- Eukarya have eukaryotic cells.
- Like the bacteria, they have membranes composed of unbranched fatty acid chains attaches to glycerol by ester linkage.
- Not all eukarya possess cells which a cell wall, but for those eukarya having a cell wall that wall contains no peptidoglycol.
- Eukarya contain rRNA that is unique to the eukarya as indicated by the presence of molecular regions distinctly different from the rRNA of Archaea and Bacteria.

## MICROSCOPY

Microscope is an instrument used to observe the objects which are not visible to our naked eye. Faber (1625) used the term microscope and it is derived from two Greek words namely, Mikros= Small ; Skopian= To See.

Z. Janssen (1590) invented simple microscope composed of two lenses to magnify the smaller object. Antony Van Leeuwenhoek (1667) who was wrongly credited as inventor of compound microscope actually invented simple microscope by using convex lenses of high magnification power up to 300x. Robert Hooke (1668) invented compound microscope with two kinds of magnifying lens systems namely objective lens system and ocular lens system.

### Types of Microscopes:

Basically microscopes are classified into two main types namely:

1. Light microscopes
2. Electron microscope

- 1. LIGHT MICROSCOPES:** In these, light rays constitute the source of illumination to focus the object or specimen. These include;
  - a. Simple microscope- It contains single lens system to magnify the specimen.
  - b. Compound microscope- It contains two lens systems to magnify the specimen.
- 2. ELECTRON MICROSCOPES:** In these Electron beam constitute the source of illumination.

*Light microscopes are of following types:*

1. Bright field microscope
2. Dark field microscope
3. Fluorescence microscope
4. Phase contrast microscope
5. Ultraviolet microscope
6. Interference microscope

## COMPOUND MICROSCOPE

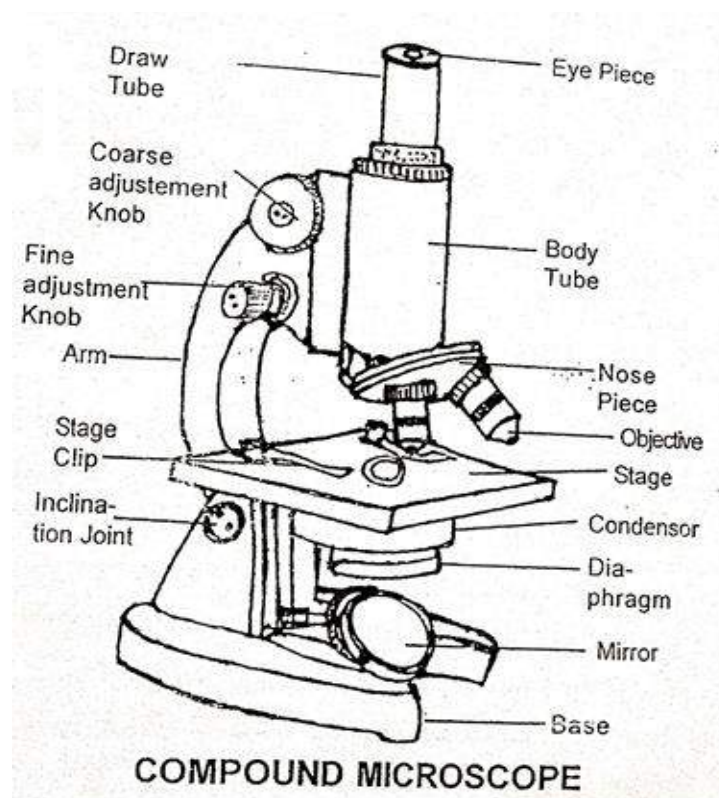

It is an optical instrument used to observe the specimen, which is not visible to our naked eyes.

### Parts of microscope

- *Eye piece*: it is placed on top of the draw tube of the microscope. It contains two plano convex lenses of which upper smaller one is eye piece and lower larger is field lenses. Eye piece magnifies primary image of the specimen and produces is secondary image.
- *Body tube*: it is cylindrical tube with upper narrow draw tube. It holds eye piece at one end and objectives at other end at the proper working distance.
- *Coarse adjustment*: it helps to move the body tube up and down to get rough focusing of the specimen.
- *Fine adjustment*: it also helps to move body tube up and down, but very slightly. It helps to get fine adjusting (focusing) of the specimen.
- *Arm*: it holds body tube coarse adjustment and fine adjustment.
- *Nose piece*: it is fixed to the lower end of the body tube. It holds objective of different magnifying powers, like, 10X, 45X and 100X. it permits the interchange of objectives from low power to high power and vice versa.

- *Objectives*: these contains plano-convex lense of different magnifying power, where magnifying power of low power the objective is low, high power objectives is 45X and oil immersion objective is 100X, objective magnifies specimen and produces its magnified primary image.
- *Stage*: it provides the place for the specimen slide over whole image in it.
- *Stage clip*: this helps in firm attachment of specimen slide on the stage.
- *Condenser*: it is a large plano-convex lens placed below the hole of the stage. It collects, condenses and focus the light rays in the focus of thick beam on the specimen.
- *Diaphragm*: it is placed below the condenser, it helps to relate amount of light rays which are pairing through it.
- *Mirror*: it reflects the light rays through the diaphragm. Condenser and hole is the stage concave mirror is used to focus the natural light rays, plane mirror is used to focus the electric light rays.
- *Base/foot*: it bears complete weight of the microscope and gives support to it.

***Operation of the compound microscope to observe specimen slide:***

- Bring microscope to the normal vertical position of the microscope is tilted.
- Fix the lower objective (10X) of the microscope to its proper position by operating nose piece.
- Keep the diaphragm is fully open condition by operating the node of the diaphragm.
- Adjust the concave mirror of the microscope is such a way that bright light can be seen through the eye piece.
- Keep specimen slide on the stage over the whole in it.
- Bring the lower power objective near to the specimen slide by operating coarse adjustment or fine adjustment.
- After focusing the specimen slide to this stage with the help of stage clips.

**DARK FIELD MICROSCOPE (DFMS):**

It is a compound microscope with optical lens units in which microscopic field is dark, while object appears bright.

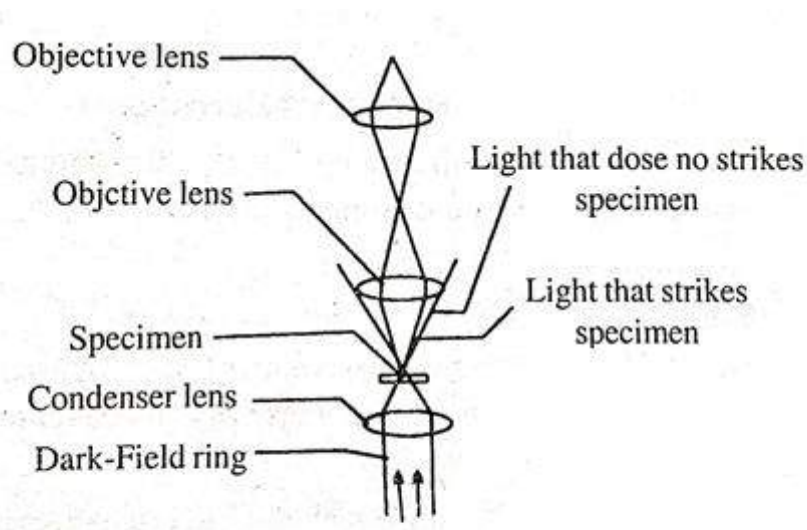

### ***Dark field Microscopy***

In the dark field microscopy, the microbes are observed as bright objects against a dark background. This is achieved by fitting a special kind of condenser (Abbe's condenser) with an opaque disk that can direct the light path from the source of illumination. In the dark field microscope a special condenser fits in to the sub stage in place of the ordinary condenser.

The central of this special condenser is opaque, so none of the central light rays can pass through it, and the object is illuminated only with very oblique rays, which are almost parallel to the stage.

Most of the light directed through the condenser does not enter the objective thus the field is essentially dark. However if transparent medium contain objects (microbes/cells) that differ in their refractive index, there will be scattering of light by reflection and retraction.

The scattered light will enter the objective and thus the object will appear bright in an otherwise dark field. For low power magnification we usually employ Abbe condenser but, for higher magnification additional condensers such as carboid and paraboloid are employed with other objectives.

Dark field microscopy is used for the examination of live, unstained preparations of microbes or other specimen suspended in fluid and is useful for diagnosis of disease. The bacterial motility can be studied by using dark field microscope. It is especially useful for the study of very small and delicate organisms such as spirochetes.

**Uses:** It is used to observe living unstained specimen particularly those which stain poorly.



## PHASE CONTRAST MICROSCOPE (PCM)

It is useful for visualizing internal structure of transparent living unstained cells. This microscope was originally developed by **Zernike** in 1935, hence called *Zernike microscope*. Zernike awarded Nobel Prize in the year 1953 for the discovery of principle behind phase contrast microscope.

The construction of this microscope is based on the principle that through biological specimens are highly transparent to visible light, they cause phase transitions in the transmitted radiations. These differences that results from small differences in the refractive index and / or thickness of different parts of object can be made clearly detectable with this microscope.

### Structural Features:

PCM in its structural features is similar to that of bright field compound microscope but with the following 2 additional parts:

1. *Annular diaphragm (AD)*: It has circular opening to allow hollow cone of light and placed in the place of normal diaphragm.
2. *Phase shifting plate (PSP)*: It is a thick circular glass plate with thin annular region, which coincides with hollow cone of light coming through the annular diaphragm. It is placed above the upper lens in the objective.

### Working Principle

When the light rays of same frequency passes through transparent object (glass plate) having thicker and thinner regions, they refract at different degrees and results different phase of light, where light rays travels slowly through the thicker region of the glass plate and light rays travels fast through the thinner region of glass plate. This is the principle involved in the working of phase contrast microscope (PCM).

Similarly when the light rays passes through the different components of the cell such as nucleus, mitochondria, chloroplast etc. having different thickness, they refract at different rates. These results in different phases of light, phase contrast microscope convert all such different phase of light into visible variations. Hence different components of the cell can be seen when the cell is observed under PCM.

### Working method

When hollow cone of light is focused on the specimen through the annular diaphragm, light rays at the point of specimen split into direct rays and refracted rays. Direct rays pass through the objective lens and thinner annular region of PSP. Refracted rays by the cellular objects passes through the objective lens and thicker region of PSP.

Direct rays are more advanced over refracted rays but with a little variation. PSP convert such little variations in phases of light into visible variations. As a result of this different parts of the cell show different brightness and darkness in the final image

**Uses:** PCM is used to observe different components like nucleus, mitochondria, chloroplast etc. in unstained living cells,

### CONFOCAL MICROSCOPY

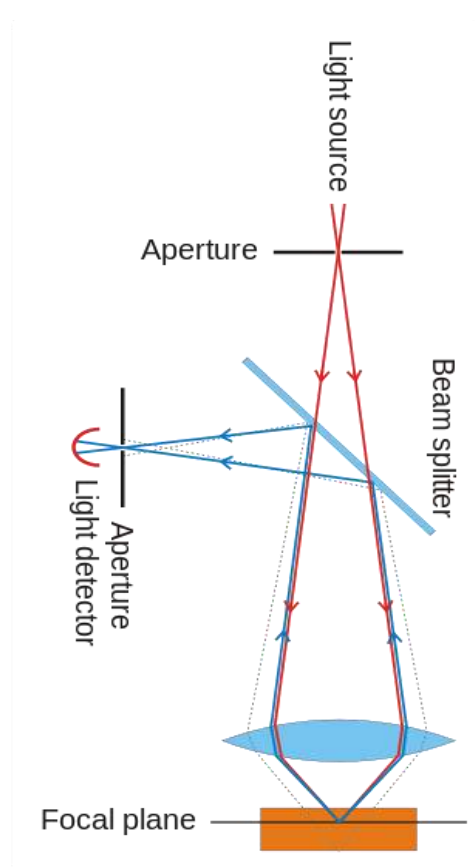

An optical imaging technique for increasing optical resolution and contrast of a micrograph. Radiations emitted from laser cause sample to fluoresce. Uses pinhole screen to reduce high resolution images. Eliminates out of focus, So images have better contrast and are less hazy. A series of thin slices of the specimen are assembled to generate a 3-dimensional image. Is an updated version of fluorescence microscopy.

**Principle:**

In confocal microscopy two principles are typically used:

1. A pinhole is placed in front of the illumination source to allow transmission only through a small area.
2. This illumination pinhole is imaged onto the focal plane of the specimen. i.e. only a point of the specimen is illuminated at one time.
3. Fluorescence excited within the focal plane of the specimen will go through the detector pinhole.
4. Scanning of small sections is done and joined them together for better view.

**Working mechanism:**

Confocal microscope incorporates 2 ideas:

1. Point-by-point illumination of the specimen.
2. Rejection of out of focus of light.
  - Laser provides intense blue excitation light.
  - The light reflects off a dichoric mirror, which directs it to an assembly of vertically and horizontally scanning mirrors.
  - These motor driven mirrors scan the laser beam across the specimen.
  - The specimen is scanned by moving the stage back and forth in the vertical and horizontal directions and optics are kept stationary.
  - Dye in the specimen is excited by the laser light and fluoresces.
  - The florescent (green) light is descanned by the same mirrors that are used to scan the excitation (blue) light from the laser beam.
  - Then it passes through the dichoric mirror.
  - Then it is focused on the pinhole.
  - The light passing through the pinhole is measured by the detector such as photomultiplier tube.
  - For visualization detector is attached to the computer, which builds up the image at the rate of 0.1-1 second for single image.

**Applications:**

1. Confocal microscopy allows analysis of florescent labeled thick specimens without physical sectioning.
2. Three dimension reconstruction of specimen.

3. More colour possibilities- because the images are detected by a computer rather than by eye, it is possible to detect more colour differences.
4. Improved resolution.

### **FLUORESCENCE MICROSCOPE (FMS):**

It is an ordinary compound microscope with the two structural features like special type of filters and UV light rays transmitting condenser. Since UV light rays will be the source of illumination for this microscope, it is also called **UV Microscope**.

In this microscope invisible UV rays are converted into visible fluorescent rays, hence it is named as Fluorescence Microscope.

#### **Structural features**

Structural features of fluorescence microscope are similar to that of bright field microscope except for the following:

In Fluorescence microscope

- UV rays transmitting condenser is used in the place of normal condenser.
- two special kinds of filters are used, they are
  - a. *Excitation filter or Primary filter* - This is placed in between specimen side and condenser just below the stage. This filter allows only UV rays and light rays of shorter wavelength to pass through it.
  - b. *Barrier filter or Secondary filter* - This is placed in between two lenses of eyepiece. This filter acts as barrier for the UV rays and allows only fluorescent light rays.

#### **Working Principle:**

Certain chemical dyes when exposed to UV rays, they absorb invisible UV rays and emit them in the form of visible fluorescent light rays. This is the principle involved in this microscope.

Regarding the principle involved in the magnification of the specimen, it is similar to that of Bright field microscope.

#### **Working method:**

1. The bacterial cells which are to be observed under the fluorescent microscope are to be stained with fluorescent dye like acridine.

2. When such slide is observed under the microscope, fluorescent dye of the bacterial cells absorb UV light rays coming from UV rays transmitting condenser and emit them in the form of visible fluorescent rays. As a result of this bacterial cells are made visible better than that of normal stained bacterial cells.

Uses: Fluorescence microscope is used to get structural details and biochemical events going on in the bacterial cells, whereas this is not possible with normal microscope.

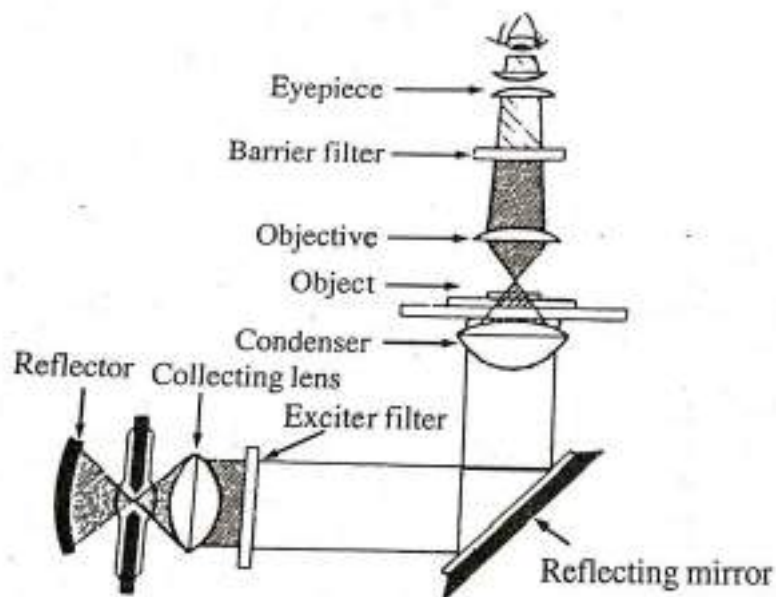

Diagram to illustrate the component parts of the fluorescent microscope.

### **ELECTRON MICROSCOPE:**

It is a magnifying instrument in which electron beam constitute the source of illumination.

The wavelength of the electron beam is  $0.5\text{m}\mu$ , hence it is possible to resolve the object even as small as  $1\text{m}\mu$  ( $10\text{\AA}$ ) size. In compound microscope it is not possible to resolve the object having size less than  $0.1$  micron ( $100\text{m}\mu$ ).

Resolving power of electron microscope is 200 times more than that of compound microscope, where it magnifies the object 1,00,000 times or more of its original size.

## Principle of Working

In the electron microscope, the source of illumination is the beam of electrons. In order to understand the working principle of electroscopes, one must first understand some elementary properties of electrons.

The electrons are negatively charged sub atomic particles that around the atomic nucleus at high velocity in specific electron orbits.

In 1924 De Broglie working on electrons proposed the dual nature of electrons i.e., electrons can behave both as a particular as well as waves and should have both a fixed wavelength and frequency. The wavelength of the electrons is calculated by De Broglie's formula.

$$\lambda = \frac{h}{mv}$$

v → velocity

m → mass

h → plank's constant

*Electron microscopes are of 2 basic designs:*

1. Transmission electron microscope (TEM)
2. Scanning electron microscope (SEM)

### **TRANSMISSION ELECTRON MICROSCOPE (TEM)**

M. Ruska first developed TEM in 1931, for which he was awarded Nobel Prize in 1986. In TEM Electrons are made to transmit through the specimen to produce the magnified image/ photograph of the specimen.

TEM has resolution limit  $10\text{\AA}$  and resolution power 400 to 2000 times more than that of compound microscope.

*Structural features of TEM:* it consists of the following units:

1. Electron gun: it consists of Tungsten filament. This filament when heated emits electro-magnetic rays (electron).
2. Electromagnetic condenser: it condenses electromagnetic rays into a thick electron beam.
3. Perforated metallic grid: it provides the place to keep the specimen to be observed under the microscope.
4. Electromagnetic objective: it magnifies the specimen and produces final image.

5. Fluorescent screen: it traps the final magnified image of the specimen.

Above parts are assembled in a vacuum chamber as one unit.

**Working principle:** it is similar to that of principle involved in working of light microscope, but here electron beam is used as the source of illumination. Electromagnetic condenser is used to condense electromagnetic radiations.

Electromagnetic objective and electromagnetic ocular are used as magnifying units. Electromagnetic rays when passes through the specimen and electromagnetic objective, magnified primary image of the specimen will be obtained.

When electromagnetic rays further passes through the electromagnetic ocular, highly magnified secondary image of the specimen will be obtained.

**Working method:**

**Preparation of the specimen:** the specimen which is to be observed under TEM is subjected to dehydration, freezing, ultra sectioning and staining with metals of high atomic weight like gold, platinum, uranium. Then the specimen is placed on the perforated metallic grid of TEM.

**Focusing of the specimen:** when tungsten filament is heated in the electron gun, it emits electron. These electrons are allowed to pass through the electromagnetic condenser, specimen, electromagnetic objective and finally through the electromagnetic ocular to get the magnified final image of the specimen on the fluorescent screen. This image can also be recorded on photographic plate.

**Uses:**

- it is used to magnify the specimen having size between  $1\mu$  to  $100\mu$ .
- Used to study ultra-structure of the specimen.

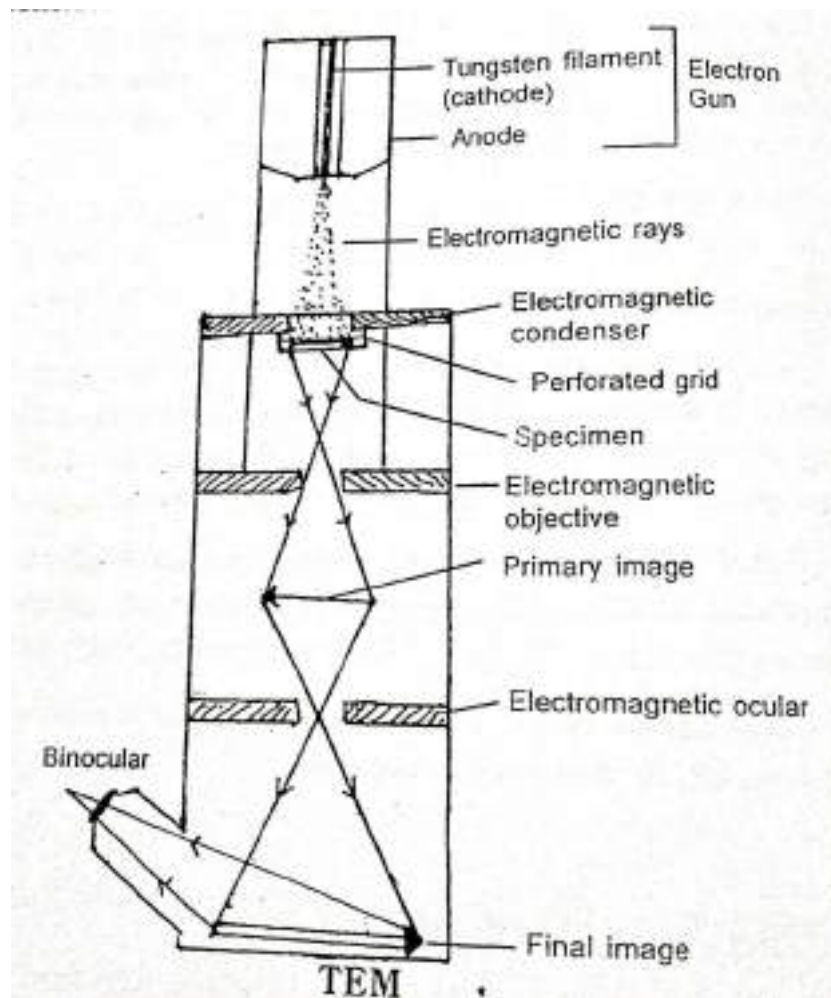

## SEM

Dennis Mc. Mullan first developed SEM in 1948. In this microscope electrons are reflected from the specimen instead of passing through it, hence electrons scan only surface details of the specimen. Resolving power and resolution limit of this microscope is less than TEM.

**Working principle:** it is same as that involves in TEM, but unlike TEM, here electrons scan the surface details of the specimen.

**Working method:** specimen which is to be observed under SEM is to be freeze dried and coated with metal vapors like gold, platinum or nickel by using sputter coater. Specimen is then placed in vacuum chamber. When electron beam is focused on the specimen, image forming secondary electrons will be emitted from the metallic surface of the specimen. These electrons will be collected from the detector. This detector generates electron signals. These signals built magnified image of the specimen on a screen of cathode ray tube just like TV camera scan and produce image of the specimen on TV screen.



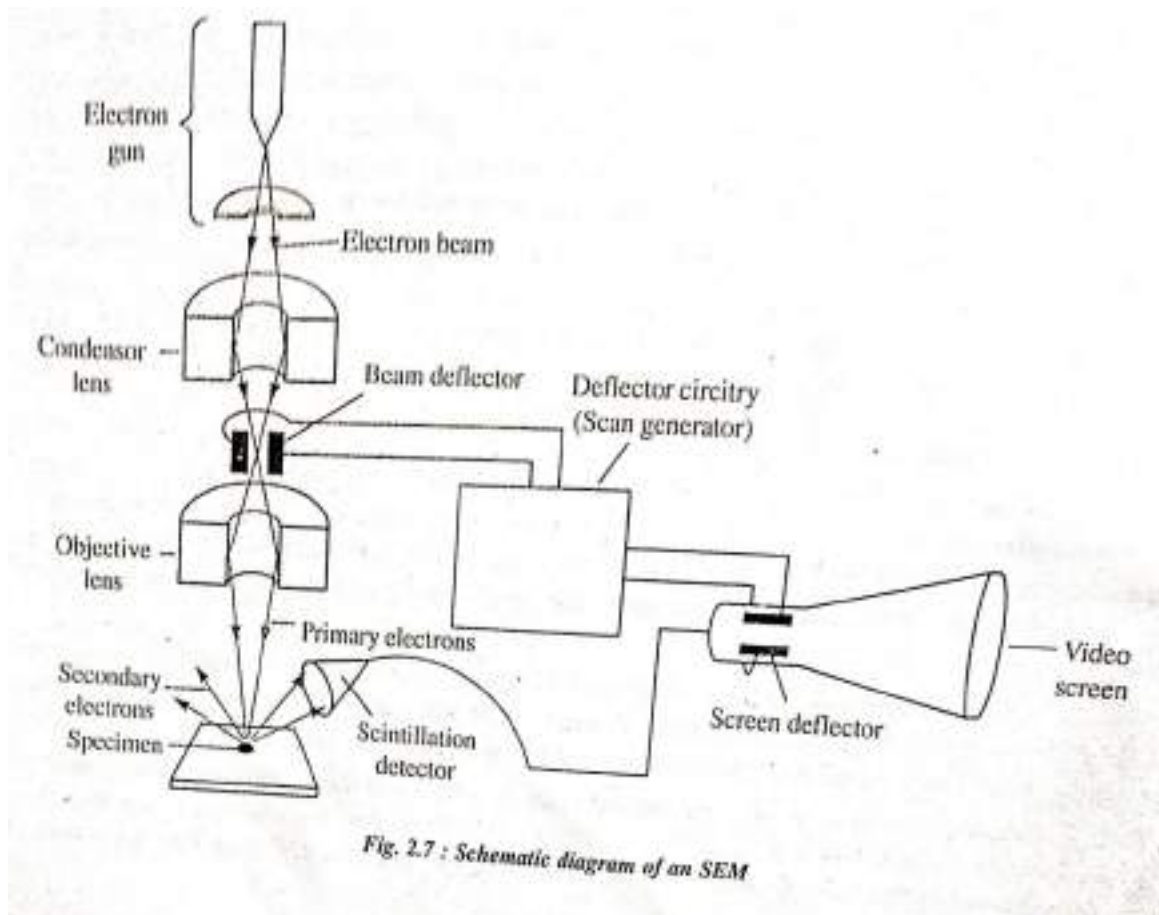

*Fig. 2.7 : Schematic diagram of an SEM*

## UNIT-2: MICROBIAL TECHNIQUES

### Introduction

The control of microbial growth is most essential to limit the distribution of valuable nutrient sources and to prolong the life of perishable materials. Microbes are ubiquitous; Microbes grow and multiply under favourable conditions. In the laboratory culture technique they are allowed to grow and multiply for their study.

But under certain circumstances, it becomes necessary to destroy, remove or suppress the growth of microbes by practical methods as they cause contamination, diseases and decay and this is called microbial control of microbes is necessary in several situations.

- To prevent the transmission of pathogenic microbes and check the spread of the disease in plants animals including man.
- To prevent the contamination of pure cultures in scientific and medical laboratories.
- To prevent the inference by unwanted microbial contamination in industrial processes.
- To prevent the decomposition and spoilage of food and food products,
- To prevent the growth for research studies, so that one microbe is not mistaken for the others.

The microbes can be inhibited eliminated or killed by numerous physical chemical and other means. The agents which act against microbes are called "*antimicrobial agents*". Varieties of microbes differ greatly in their susceptibility to antimicrobial agents.

Many biological characteristics influence the rate at which the microbes are killed or inactivated by various antimicrobial agents. Many a time the choice of an antimicrobial agent depends on the type of microbe, (spores or growing vegetative cells). Its stage of growth (young or old), the environment in which it is present (air, water, soil, food, skin, sewage etc.).

It is prerequisite for one to know some common terms used in connection with microbial control. Some of them are listed below.

### ANTISEPTIC (ASEPTIC)

Acting against or opposing sepsis putrefaction or decay by either preventing or arresting the growth of microorganisms. Aseptic conditions are necessary in hospitals, dealing with patients, with communicable diseases and in microbiological laboratories.

Microbiology practical involves the culture of microbes in an aseptic condition and staining of microbes for their observation. Hence, the following 2 main types of techniques are developed.

1. Sterilization technique
2. Staining technique

### **STERILIZATION TECHNIQUE**

Microbial culture requires 100% sterilization of glass wares, metal foils and culture media, which are used for microbial culture.

‘The process by which an article, surface or medium is freed of all microbes either in vegetative state or in spore state. It is the most efficient method of killing all microbes from a given area, surface, object or material’.

#### **Methods of sterilization**

Sterilization of glass wares and culture media can be done by the following 3 principle methods.

1. Physical method
2. Chemical
3. Radiation

**Physical method of sterilization:** this include killing of microbes by applying moist heat as in steaming or dry heat as in hot air oven, or by filtration.

#### ***Application of physical methods of sterilization***

- It is the most suitable method of sterilization for moisture sensitive material. Ex: oily substances and dry powder.
- It is suitable for assembled equipment providing sufficient time for penetration. Ex: all glass, syringes, test tubes etc.
- It is less damaging to glass and metal equipment than moist heat.
- This method is economically safe.

*Sterilization of glass wares and culture media can be done by physical methods using.*

- |   |                     |   |                   |
|---|---------------------|---|-------------------|
| 1 | Hot air oven method | 3 | Laminar air flow  |
| 2 | Autoclave           | 4 | Bacterial filters |

## AUTOCLAVE

It is an electrically operated instrument for sterilization of glass ware and culture medium by moist heat method or steam heat method.

*Principle:* when glass ware and culture media contaminated with microbes are exposed to moist heat or steam heat in the autoclave at 121° under 15 lb's for 15-20 min. moist heat kills the microbes by oxidising cellular components. This is the principle involved in sterilization of glass ware and culture medium by moist heat method or steam heat method.

### *Working method*

1. Cover all the glass ware and culture medium in the conical flask with newspaper separately, then keep them in autoclave and switch on the instrument.
2. Set the required temperature and required process by operating temperature setting knob and process setting knob.
3. Allow the instrument in working condition for 15 – 40 min. then switch off the instrument. Allow it to cool for room temperature.
4. Take out glass wares and culture media kept for sterilization and use them in microbial culture practicals.

### *Applications or uses*

- Autoclave is used to sterilize the glass ware like beakers, conical flask, petridish and culture media.
- It is also used to sterilise used culture plates and tubes before their discard.

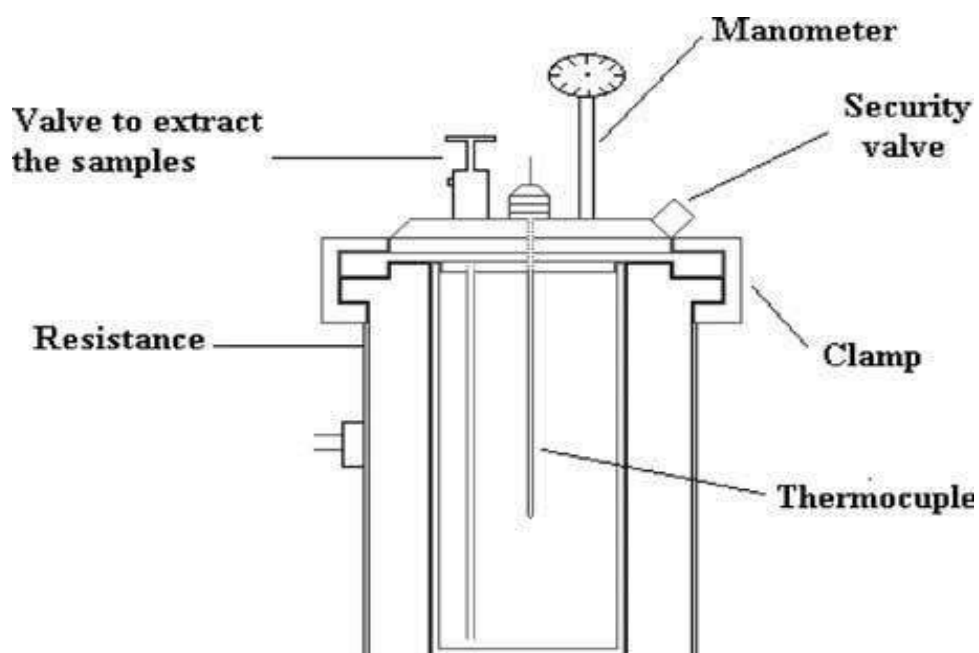

## HOT AIR OVEN

It is an electrically operated heat isolated instrument used for sterilization of glass wares by dry heat method.

*Principle:* when glass wares contaminated with microbes are exposed to dry heat in the hot-air oven at 180° for 2-3 hours, dry heat kills the microbes present on the glass wares by oxidizing cellular components of microbes. This is the principle involved in sterilization of glass wares by dry heat method.

*Working method:*

1. Keep all the glass wares (beaker, pipette, conical flask, test tubes, petriplates etc.) which are to be sterilized inside the hot air oven.
2. Switch on the instrument set the temperature to 180° C by operating temperatures setting knob.
3. Allow the instrument in working condition face 2-3 hours. Then switch off the instrument allow it to cool for room temperature.
4. Then take out the glass ware kept for sterilization and use them for microbial culture practical.

*Application or uses*

Hot air oven is used for sterilization of glass wares are beaker, conical flask, test-tube, petriplates etc by dry heat method.

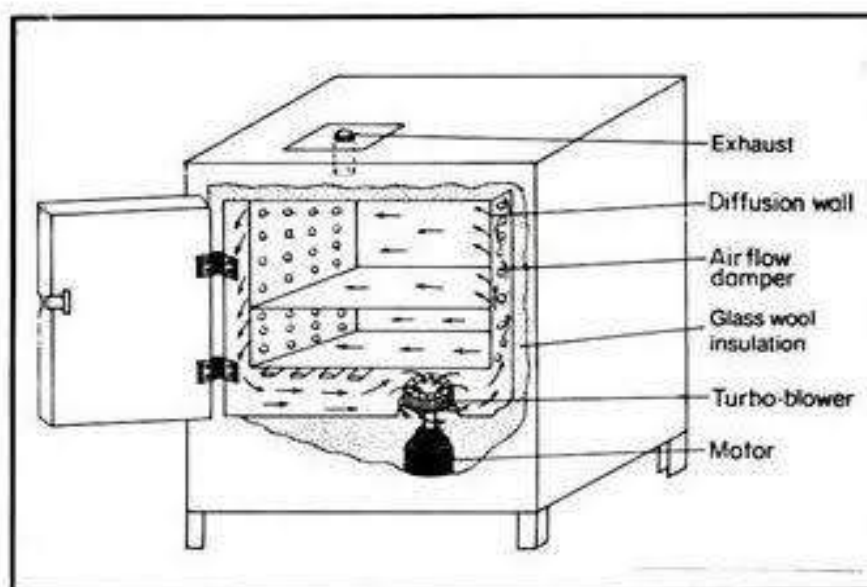

## LAMINAR AIR FLOW

Laminar air flow is defined as air moving at the same speed and in the same direction, with no or minimal cross-over of air streams (or 'lamina').

It is an electrically operated instrument used to create microbial free atmosphere required for inoculation process. In this instrument sterilization is done by filtration method and sterilization method.

*Principle:* when air contaminated with microbes passes through the HEPA (High Efficiency Particulate Air Filter) having pore size less than 1 micron, the entry of microbes along with the air through the HEPA filter is prevented, this is the principle involved in creation of microbial free atmosphere in LAF (Laminar Air Flow).

When UV tube is on in LAF, UV rays also cause the sterilization by oxidising cellular component of the microbes. This is the principle also involved in sterilization of air in the LAF.

### *Application or uses*

LAF is used for inoculation of microbial sample in to the culture media in the culture tube or culture plate under aseptic atmosphere.

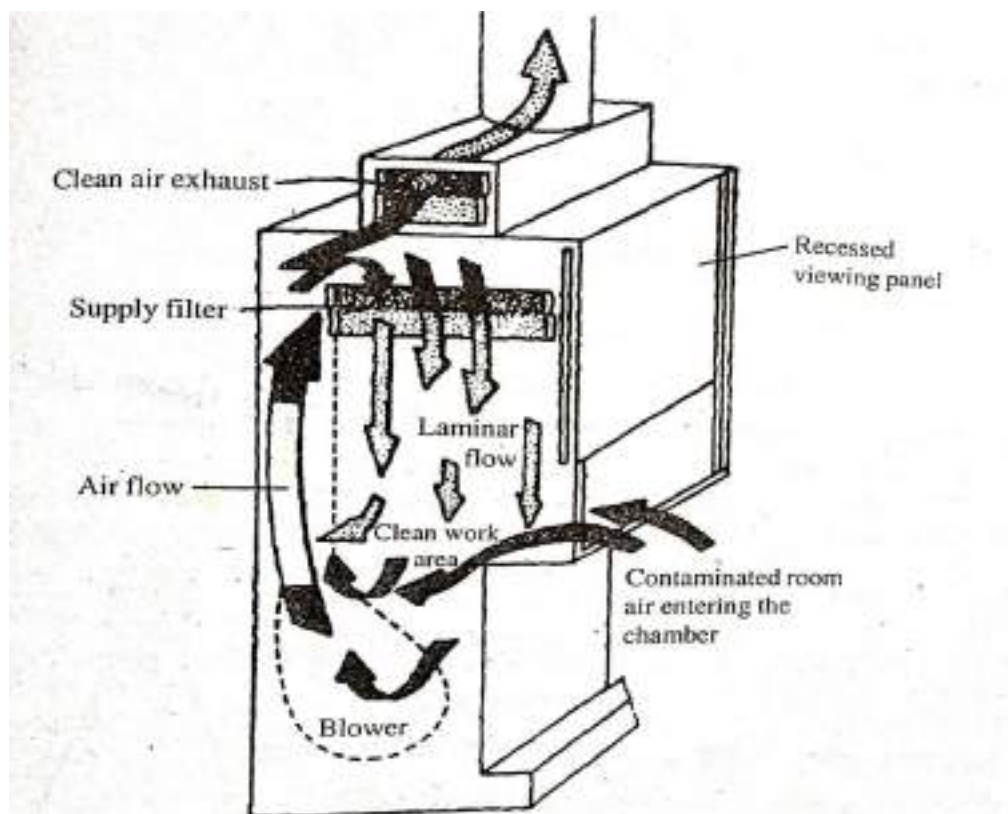

## Inoculation

The process of transfer of microbial sample with the help of inoculation loop into the culture media in the culture tube or culture plate is known as inoculation.

## BACTERIAL FILTERS

Sterilization of liquid culture media, blood serum, water, which are to be used for bacterial culture practical, can be done by filtration method using bacterial filters.

### Principle:

Bacterial filters are having pore size less than the bacterial cell size (less than 1 micron), when liquid culture media are blood serum or water contaminated with bacteria passes through the bacterial filters, the flow of bacteria through the pores will be prevented. This is the principle involved in sterilization by filtration method.

## Kinds of bacterial filters

*Bacterial filters include the following 3 types:*

1. Seitz filter
2. Sintered glass filter
3. Membrane filters

## SEITZ FILTER

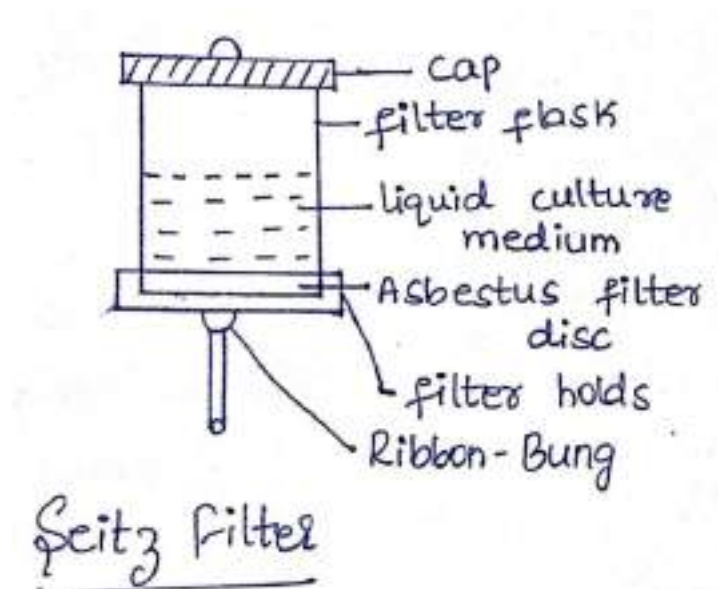

Seitz filter (Asbestos filter), is a kind of bacterial filters used for sterilization of liquid culture medium. It consists of cylindrical filter flask with screw cap at the top and filter holds at the base.

It consists of sheets or discs composed of compressed asbestos filter. The filters are 2-6 mm in thickness. They contain washed asbestos fibres, cellulose and some alkaline earth metals, such as magnesium compounds. The thickness of asbestos fibres and the gap between them determines the efficiency of the filter. These filter sheets or discs are clamped in a metal holder and either a negative or positive pressure is applied. Seitz filters are very soft and can be easily damaged by even rough handling.

### *Applications*

It is used for sterilization of liquid culture medium, blood serum, water by filtration method.

## **SINTERED GLASS FILTER**

### **Sintered glass filters (Fritted glass filters) [Morton filters]**

It is prepared by heating finely pulverized glass in and fusing it in disc form in a suitable mold at the temperature just below its melting point. The discs are fused in to Buchner type or pyrex glass funnels. Either by a rubber stopper or through a ground glass joint. The fitted glass filters are designed in several porosities, these may be classified in to extra coarse, coarse, medium, fine and ultra-fine in the order of decreasing porosity, and sintered glass filters are useful for small volume preparation.

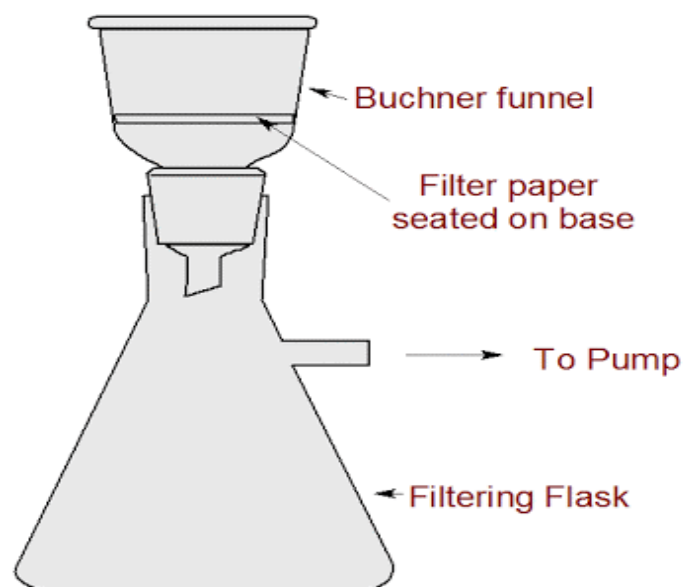

*Sintered glass filter*



### *Application or uses*

Sintered glass filter has less absorption property for microbes and chemicals. Hence, it is very easy to clean for its reused.

### **MEMBRANE FILTER (Ultra filters)**

It is a kind of bacterial filter used to separate microbes present in water or liquid culture medium. It is made up of cellulose acetate filter disc.

Membrane filter unit consists of funnel over the receiving bottle. Between the funnel and receiving flask cellulose acetate membrane filter disc is mounted in the filter holding device. Receiving flask is connected between suction pump.

### *Advantages or Uses of membrane filters*

- Bacteria are removed by sieving.
- Because the membranes used are very thin so absorption of medicament is negligible.
- A new disc is used for every disk of operation.
- Filtration is quite rapid.
- They do not liberate particles or chemical substances to filtrate.
- It is used to sterilize water or liquid culture medium used for microbial culture practical.

### *Merits*

It serves as not only bacterial filter but also helps to identify types of bacteria present in the water sample or culture media. This involves the culture of membrane one disc changed with microbes in the nutrient agar culture medium.

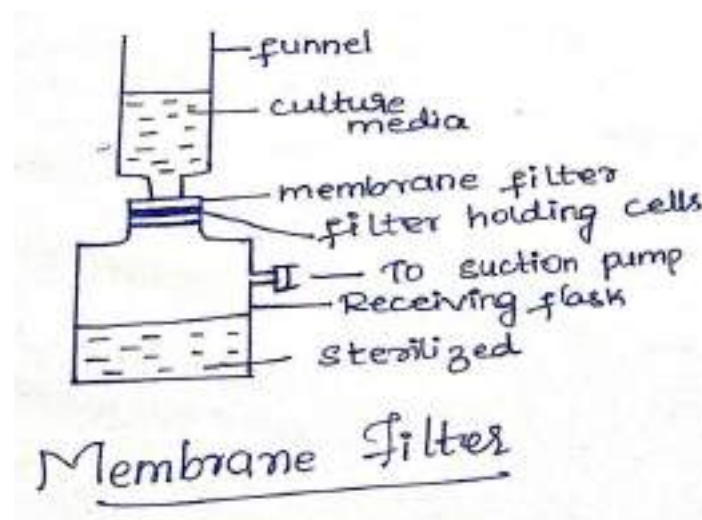

## RADIATION METHODS

### Sterilization by radiation method

Sterilization of glass wares can also be done by radiation method. Sterilization by radiations is called cold sterilization, because without boiling or heating microbes can be destroyed by radiation.

Energy transmitted from alpha, beta, gamma and X-rays and UV rays in the form of radiations. Based on mode of action on the chemicals radiations are classified into the following 2 groups:

- 1. Ionizing radiations:** radiations which penetrate into the chemical molecule and cause the ionisation of atoms into the ions are called ionising radiations. Ex: radiations transmitted by alpha, beta, X rays.

*Effects:*

- a. Ionising radiations penetrates into the bacterial cell and causes the ionisation of atoms of DNA molecule.
- b. These results in death of microbe.

- 2. Non-ionising radiations:** radiations which never penetrate into the chemical molecule and never cause the ionisation of atoms into the ions are called non ionising radiations. Ex: radiations transmitted by light rays of shorter wave length and ultraviolet rays.

*Effects:*

Non ionizing radiations penetrates into the bacterial cell and never causes the ionisations of atoms, however, they causes damages in a DNA molecule in the cell. This results in death of the microbes.

### UV RAYS

- Ultraviolet rays are widely used for sterilization purposes.
- The ultraviolet rays with wavelength around 2650 Å have potent bactericidal capacity. At this wavelength it is toxic to both spores and the vegetative cells.
- Many germicidal lamps are available that can emit high concentration of UV light in the most effective regions 260 nm - 270 nm. In these lamps UV light is generated by passing electricity through vaporised mercury in quartz tubes.

The UV-light effectively reduces microbial populations in the air of closed rooms or morgue, pharmacy, toilet facility, hospital operating rooms, In aseptic filling rooms the

pharmaceutical industry food and dairy industry the UV light is used for treatment of contaminated surfaces.

Since the UV-light has very light penetration power. Even a thin layer of glass filters off large amount of light. Hence only UV light can be used to destroy the microbes on the surface of an object.

#### *Mechanism of action*

Ultraviolet light is absorbed by many cellular materials, but most significantly the cellular DNA and induce the production of thymine dimers, in which two adjacent thymines become bonded. Such dimers interfere with proceedings of DNA replication.

The damage caused by UV light can be removed by specific intracellular enzymes by subjecting these to visible light in a process known as *photo reactivation*, The reaction is catalysed by the light dependent photolyase.

### **GAMMA RAYS**

- Gamma radiations are high energy radiations emitted from certain radioactive isotopes such as  $^{60}\text{Co}$ .
- Gamma rays have high energy short wavelength and high penetration power in to the biological tissues and are highly lethal to the DNA and other vital constituents and cause biological damage by produce hyperactive free radicals like superoxides hydroxyl ions and peroxides.
- Because of their high penetration power and microbicidal effect gamma rays are attractive for use in commercial sterilization of bulk materials such as packaged food and medical devices.
- However certain practical problems must be resolved before gamma rays could be used for large scale uses.
- The design of the equipment should be such that it should not prove to be hazardous to the user.

### **CHEMICAL METHOD OF STERILIZATION**

Sterilization of glass wares and instruments used in the microbial practical's can be done by using certain chemicals such chemicals are called sterilants.

Chemical sterilants are classified into following 2 groups.

1. **Dis-infectants:** chemical sterilants which prevent the spreading of microbes are called disinfectant. Ex: formaldehyde, phenol.
  - Disinfectants are mainly used for the sterilizing the surfaces used for an aseptic work.
  - In emergency they may be used for sterilizing the surgical instruments like forceps, scissors, knives, blades etc.
  - For this reason the acquired instruments need to wash with sterilized water.
  - The commonly used disinfectants include alcohol, iodine, chlorine etc.
2. **Antiseptics:** chemical sterilants which prevent the infection of wounds by microbes are called antiseptics. Ex: alcohol, iodine.

### **Mode of action of sterilants on microbes**

*Sterilants show the following effects on microbes.*

1. Disinfection of cell wall and cell membrane of the microbes.
2. Dehydration of the microbes.
3. Coagulation of protein content of the microbes.
4. Defunctioning of enzymes in the microbes.

### **ALCOHOL**

It is an organic solvent used as both disinfectant and antiseptic.

Ethyl alcohol in concentrations between 50-90% is effective against vegetative cells. However its maximum germicidal efficiency is exhibited in a concentration of 70% by weight.

Methyl alcohol (methanol) another alcohol is less efficient than ethanol, but it is not used as it is highly poisonous and cause harm to the users [methanol fumes can cause permanent damage to eyes]. Alcohols are mild disinfectants for practical application [70%] and are non-toxic when used for external application as antiseptics. They are effective in reducing the microbial flora of the skin and for the disinfection of clinical (oral) thermometers. 60% alcohol concentrations are effective against viruses.

#### *Mode of action*

Alcohols are protein denaturants that accounts for antimicrobial activity. It acts as dehydrating agent. As the alcohols are solvents for lipids and hence they can damage to the membrane lipids.

*Effects on microbes*

1. Disinfection of cell wall and cell membrane.
2. Dehydration of cells.
3. Coagulation of protein content of the cell.

**ALDEHYDES**

These are organic compounds with CHO group and used as only disinfectant. Ex: formaldehyde, glutaraldehyde.

Formaldehyde is one of the oldest known disinfectants. Formaldehyde and glutaraldehyde are the well-known sporicidal agents. Formaldehyde (HCHO) is a gas that is stable at high concentrations and at elevated temperatures. Commercially formaldehyde is marketed in aqueous solution as formalin that contains 37-40% formaldehyde.

*Practical applications:* In aqueous solutions it is potent bactericidal and sporicidal also has lethal effect on viruses. Formaldehyde in gaseous form (formalin) is chiefly used in disinfection and sterilization of closed areas. Humidity and temperature have profound effects on the microbicidal action of formaldehyde.

Formalin is used to preserve anatomical specimens. However, one of the disadvantages that make the use of formaldehyde less frequent is that they are irritating to tissues and eyes.

**Mode of action:** Formaldehyde readily combines with vital biomolecules such as proteins and nucleic acids and destroys them, causing a lethal effect on cells.

Glutaraldehyde is a saturated dialdehyde: It is effective against bacteria, viruses, fungi, and spores of bacteria and fungi. It is used for sterilization of urological instruments, lensed instruments, and respiratory therapy equipment.

*Effects:*

1. Denaturation of the cell
2. Coagulation of proteins of the cell.

## PHENOLS

In 1870's Joseph Lister a surgeon used phenol to reduce infection of surgical incision and wounds. Phenol however is rarely used in recent days as it is very expensive. Hence less expensive and more effective phenolic derivatives are commonly used these days. A 5% of phenol rapidly kills the vegetative cells of microbes. Such derivatives include cresols, hexachlorophene, pentachlorophenol.

*Practical uses:* Phenol and its derivatives may be either bactericidal or bacteriostatic, depending upon the concentrations used. The spores are much resist to the phenol.

The emulsions of phenols have increased germicidal property. The phenolic derivatives like have property to reduce the surface tension in addition to germicidal property. The solution of hexyl orcinol in water and glycerine has potent microbicidal property and used as an antiseptic in mouth wash, gargles-cough drops etc. Hexachloropene is a good skin antiseptic as it is surfactant. One of the widely used phenolic derivatives is the O-phenyl phenol. These are used in combination with soaps and hand wash.

### *Mode of action phenols*

Phenols have variety of microbicidal effect; depending upon the concentration of the phenolic compound and the duration of exposure the phenols solubilizes the lipids of cell membrane causing the cell contents to leak out. They also precipitate the proteins and denature the enzymes.

## HALOGENS

Halogens (iodine, chlorine, bromine and fluorine] are potent germicides. Either in their free or in combined states.

### ➤ *Iodine*

It is one of the older and most effective germicidal agents. Iodine is pungent dark brown chemical having metallic lustre. The iodine is traditionally used as a local antiseptic in households to treat wounds, cuts and scratches [2% iodine, 2% KI in 90% alcohol]. The iodine is also used in the form of "iodophores" that are mixtures of iodine with surfactant organic compounds that act as carriers and solubalizers for the iodine. Example, betadine, wesiodyne etc.

*Practical applications:* It is highly bactericidal and sporicidal agent. Aqueous solutions of iodine are chiefly used for the disinfection of the skin, sanitization of food utensils and disinfection of air and water.

*Mode of action:* iodine is a strong oxidizing agent that irreversibly oxidizes some important functional groups metabolic pathways. They also inactive many enzyme by binding to active site amino acids like tyrosine residues.

### ➤ **Chlorine**

It is the most widely used disinfectant either in gaseous form or in chemical combination with others compressed gas of chlorine is universally employed for the purification of municipal water supplies gaseous chlorine is used in large scale operations such as water purification plants as it requires a special equipment to handle. For the convenient use chlorine compounds than can be handled easily are hypochlorite.

(E.g.: Sodium hypochlorite or calcium hypochlorite, (chlorinated lime)).

Chloramines are organic chlorine compounds where one or more hydrogen atoms in imino group are replaced by the chlorine. They are used as sanitizing agent's disinfectants, or antiseptics.

Eg. Azochloramine, Dichloramine.

### **Applications**

Chlorine compounds are widely used to control microbes and thus in water treatment, in the food industry, for domestic uses and in medicine, chlorine has wide spectrum of activity against viruses. The calcium hypochlorite is used in sanitizing, utensils, dairy equipments 1% solution of calcium hypochlorite is used in personal hygiene and as household disinfectant. Higher percentages of 5-12% are used as sanitizing agents in dairy and food industry.

### **GASEOUS AGENTS**

The application of gaseous agents to control microbe has been practiced since a long time. Certain routinely used medical devices such as plastic syringes, blood transfusion apparatus and catheterization equipment's can be efficiently sterilized by the gaseous agents. The routinely used laboratory wares like plastic pipettes, petridishes and other equipments can be sterilized.

- Many gases like sulphur di oxide, chlorine, ozone, formaldehyde,  $\beta$ -propiolactone and ethylene oxide have bacterial effects.
- Nowadays ethylene oxide has become the most widely used gaseous sterilizing agent in pharmacy and medicine.
- **Ethylene oxide**
  - It is a colourless gas at ordinary temperature.
  - The mode of action of ethylene oxide to kill the microorganisms based on the process of alkylation of essential substances present in a protein molecule.
- **Formaldehyde**
  - Formaldehyde gas is used for sterilization is produced by heating formalin to a temperature of 70-75°C with steam.
  - Formaldehyde has a similar toxicity to ethylene oxide.
  - This has been used commonly for fumigating the rooms and blankets in the hospital.
- **Disinfectants**

#### *Application of sterilization by gaseous agents*

- It sterilizes surgical instruments such as catheters, needles etc.
- Polythene bags can be sterilized by it.
- It is used for fumigating the room.
- It kills bacteria and all bacterial spores.
- It is used in alcoholic solution.
- It sterilizes the laboratory.
- They also used in disinfectants include alcohol, iodine, chlorine etc.

## **ISOLATION OF MICROORGANISMS**

Microorganisms are microscopic living organisms, which may be single celled or multicellular.

The study of microorganisms is called microbiology.

### ***Basic terms***

**Culture-** population of microorganisms grown under well-defined condition.

**Pure culture-** a culture containing only one species of microbe.

**Mixed culture-**when a particular species of microbe is present in a very small number in comparison to the total number of microorganisms, such culture is called mixed culture.



**Species-** a collection of bacterial cells which share an overall similar pattern of traits in contrast to other bacteria whose pattern differs significantly.

**Strain-** is strain is a subset of a bacterial species differing from other bacteria of the same species by some minor but identifiable difference.

Microorganisms are generally found in nature (air, soil and water) as mixed populations. Even the diseased parts of plants and animals contain a great number of microorganisms, which differ markedly from the microorganisms of other environment. To study specific role played by a specific microorganisms in its environment, one must isolate the microorganisms.

The process of screening a pure Culture by separating one type of microbe from a mixture is called **isolation**.

Some common isolation methods are:

- Isolation by streak plate technique.
- Serial dilution.
- Pour plate method.
- Spread plate method.
- Exposure plate method.

### **ISOLATION BY STREAK PLATE TECHNIQUE**

In this method the tip of a fine structure wire loop called inoculation needle consists of a wooden or glass handle with a nichrome wire, the end which is bend to form a loop, is used to transfer microbes from culture broth. The streak wires are similar to wire loop except they do not have a loop. These are used to transfer culture in colony form on solid culture medium. In such cases, the colony from solid medium is streaked on the surface of nutrient Agar medium.

In such cases, the colony from solid medium is streaked on the surface of nutrient Agar medium in a sterile Petri dish.

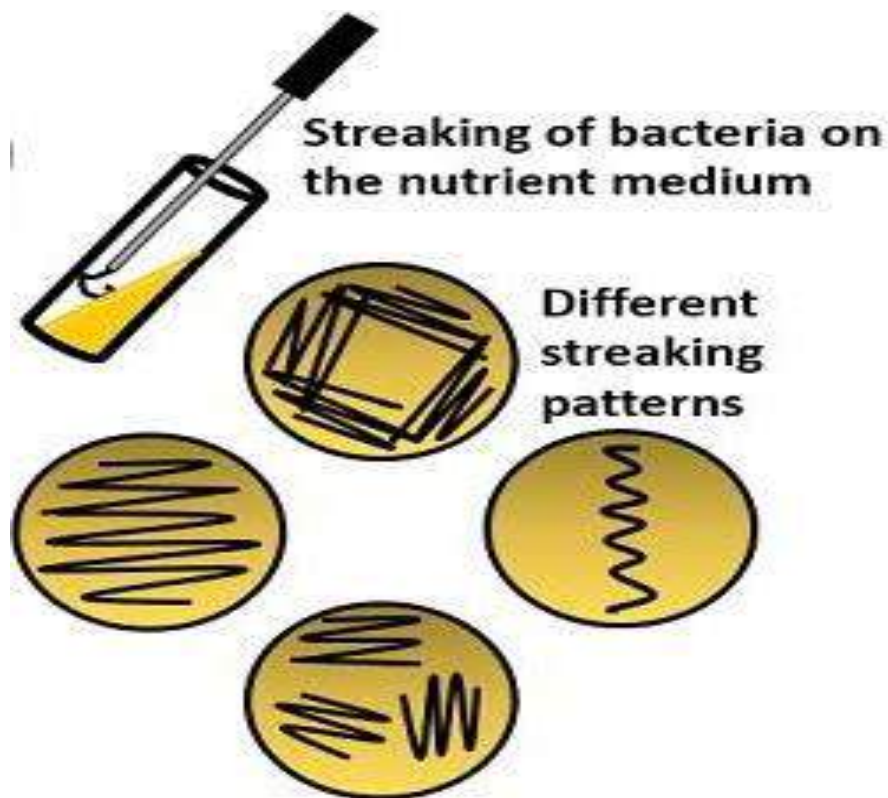

*This technique consists of the following steps:*

- Hold the broth culture containing tube in left hand and shake it.
- Sterilize the wire loop of the inoculation needle on burner flame.
- Remove the Cotton plug of the broth culture tube by buy a little finger of right hand.
- Flame the mouth of the test tube immediately.
- Keep the test tube in such a way as given in the figure; insert the wire loop to form a thin film and replace the Cotton plug.
- The thin film in the loop is streaked in either a zigzag manner by removing the loop backward and forward firmly. Care should be taken that loop should not be firmly pressed against the Agar surface.
- Incubate the Petri dish in incubator required temperature.
- Growth of the bacteria will be visible (after an overnight incubation) on the streaked marks.

## **SERIAL DILUTION**

- It is a method of stepwise dilution of substances.
- The dilution factor is kept constant, resulting in a geometric progression of concentration in a logarithmic fashion.
- Each dilution reduces the concentration of bacteria by a specific amount.

- By calculating the total dilution over the entire series, it is possible to know how many bacteria were present when the process was started.

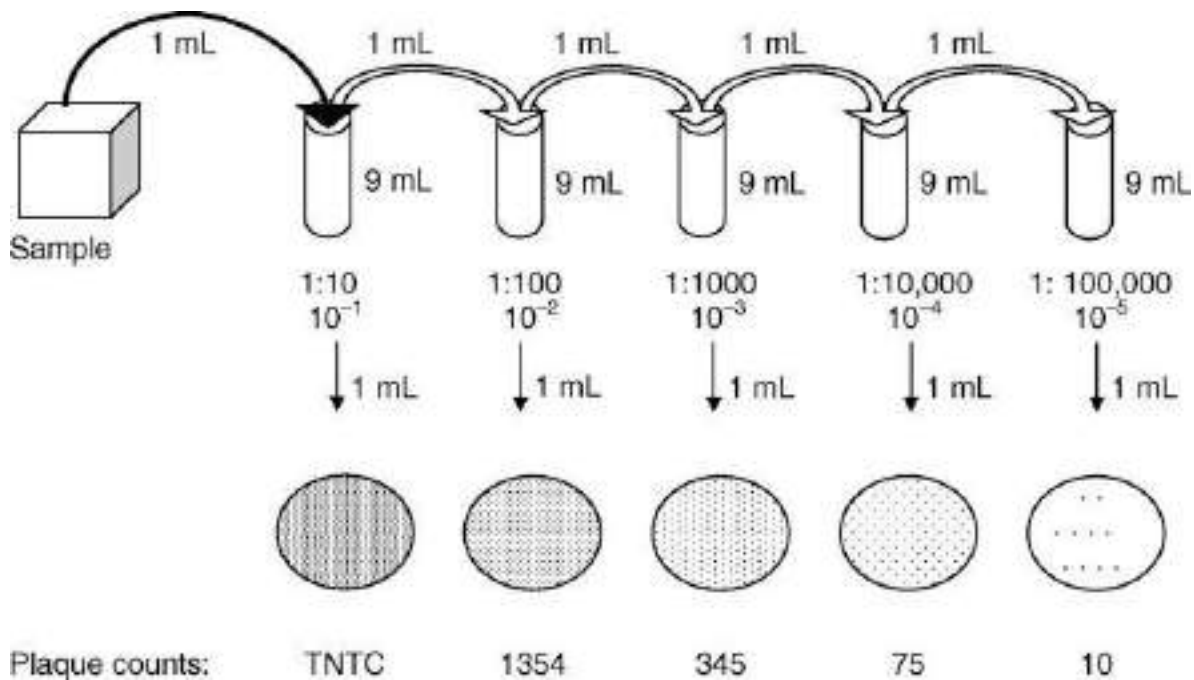

### POUR PLATE TECHNIQUE

This method is used to count the number of Colony making bacteria in liquid specimen.

- In this method a fixed amount of inoculum (generally 1 ml) is taken from a broth or sample, is placed in the centre of a sterile petri plate with the help of a sterile pipette.
- Molten cooled Agar (approximately 15 ml) is then poured onto the petri plate containing inoculum and mixed well.
- After the solidification of the Agar the Petri plate is inverted and incubated at 37° Celsius for 24 to 48 hours.
- Bacteria will grow both on the surface and within media.
- Colonies which grow within medium are very small in size and maybe confluent.
- Few bacteria which grow on the Agar plate surface are of same size and appear as those on a streak plate.

#### *Pour Plate Uses*

- This method can be used to determine the number of microbes per ml in a specimen or sample.
- It has the advantage of not requiring previously prepared plates and often used to assay bacterial contamination of food stuffs.

## Pour Plate Method

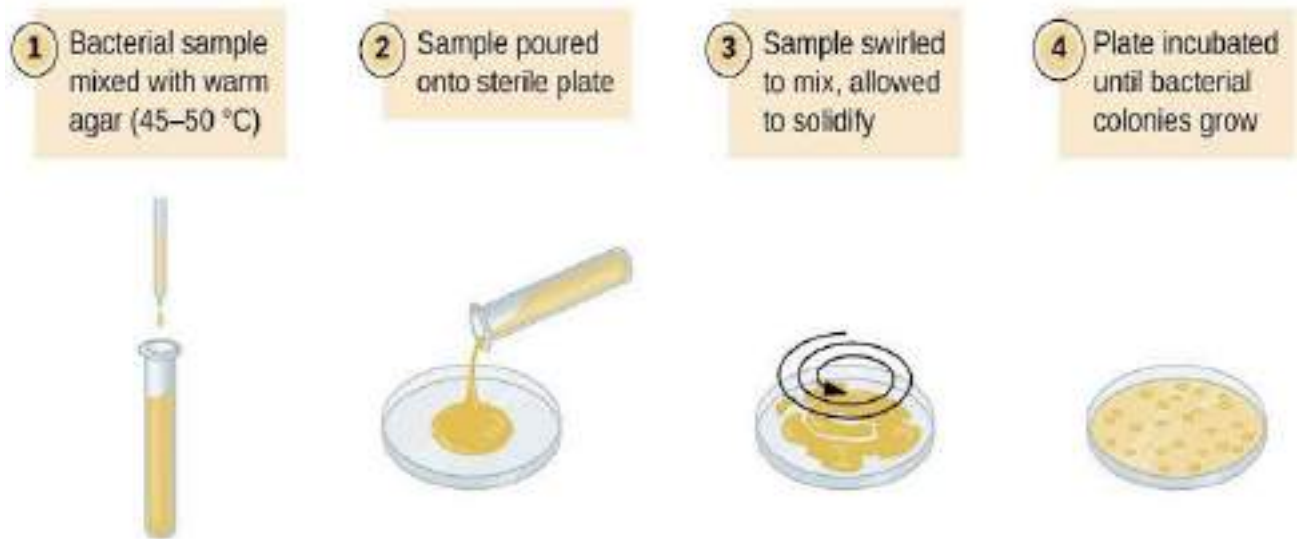

## SPREAD PLATE METHOD

- This is a technique used to readily quantify the amount of bacteria present in a solution.
- In this technique, the sample is diluted and then a little amount of it is added to the agar plate.
- Then the sample is spread over the agar surface evenly with the help of a spreader.
- After the colonies grow, the number of colonies is counted.
- The end point of our analysis is the number of colony forming units per millilitres.

## Spread plate technique

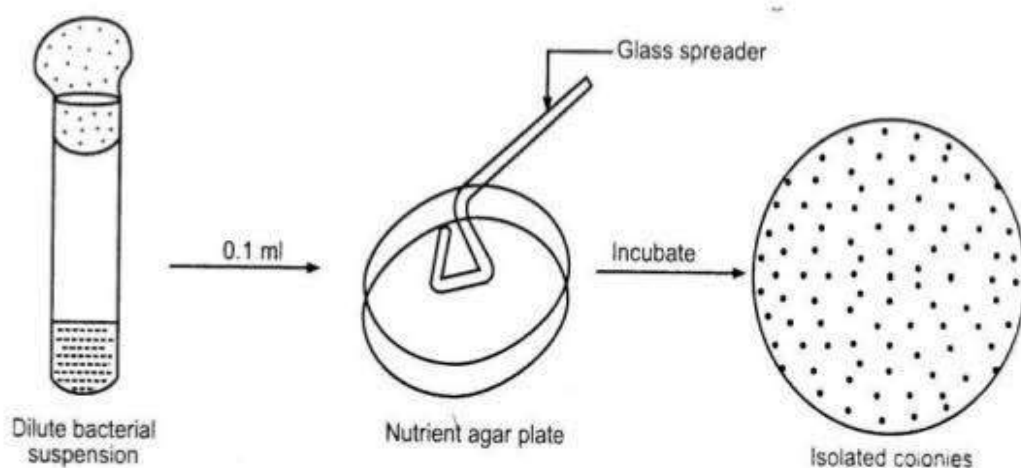

## EXPOSURE PLATE METHODS

The nutrient Agar slide/ culture medium containing a plate is exposed to the atmosphere for few minutes. After incubation (overnight or more) small colonies appear on the surface of the medium which may be transferred on a fresh medium aseptically to obtain pure culture, such technique is called sub-culturing. When the transfer is from solid medium (Agar) to liquid medium (broth), the term 'picking off' is used. In such cases the colour of the colony, their size, shape, appearance, form, consistency and optical properties are recorded.

## STAIN AND STAINING TECHNIQUES

The colouring agents impart colour to the colourless microorganisms. Due to this coloration the microorganisms become visible, so as to observe its cell shape and structure. These stains are composed of a positive and negative ion, one of which is coloured & is known as chromophore. The basic dyes are in positive ion while acidic dyes in the negative. Since bacteria are towards negatively charged at pH 7.0, thus the coloured positive ion in a basic dye binds to the negatively charged bacterial cell.

### *Advantages*

- The cells are made more clearly visible after they are coloured.
- The differences between cells of different species and within same species can be demonstrated by use of appropriate staining solution.

Chemical substances used to stain microbes are commonly called as 'dyes'. The dyes may be acidic, basic or natural dyes.

The process of staining may involve in exchange reactions between stain and the active site at the surface of the cell. A large number of dyes are available for staining microbes based on the chemical nature dyes.

*Dyes are of two types namely;*

- **Acidic dyes**- Eosin, Rose Bengal, Nigrosin, Indian ink.
- **Basic dyes**- methylene blue, basic fuchsin, Crystal Violet malachite green.

**Fixing:** usually fixation is process by which the cell can cell components of microorganisms are preserved in the same position and condition.

*Chemical fixation:* it is necessary to preserve the cell content and also necessary to preserve the large microorganisms. The chemical fixatives percolate the cell and also the cellular components. They also render the fat and protein inside the cell.

Some of the examples of chemical fixatives are ethyl alcohol, formaldehyde, Mercury chloride, etc.

*Heat fixation:* in this process, a loop full of bacterial suspension is smeared on the surface of the glass slide in such a way that the cells are separated from one another. Then the slide is gently passed over a flame to dry the smear. Then the bacterial cells are attached to the glass surface.

## **TYPES OF STAINS**

### ***1. SIMPLE STAINING***

The use of a simple stain for staining organisms is called *simple staining*. The stain like methylene blue, Crystal Violet can be since they have colour bearing ions which are positively charged since most of the bacterial cells are separately charged there is a pronounced attraction between the states and the organism.

#### **Methods of a simple staining**

To the glass slide transfer a loopfull of bacterial culture by means of a sterile inoculation loop to the centre of the glass slide, if transfers are made from solid media touch the loop lightly upon the culture and transfer to a drop of water that slightly and mix until a slight turbid results, spread the drop over the slide and allow it to dry. Fix the dried by passing the slide through the flame, slide over 2- 3 times.

Then flood the fixed smear with several drops of dyes and allow to remain for the following intervals:

Carbol Fushen	-	10-30 sec
Crystal Violet	-	30-45 sec
Methylene blue	-	3-5 sec

Then wash the slide with excess of water to remove stain and remove the water droplet with the help of blotting paper and then observe under microscope. The simple stain helps us in determining the shape, size and arrangement of the cells in bacteria.

## 2. **STRUCTURAL STAINING**

Some bacteria are capable of changing in the dormant structure that are metabolically inactive don't grow and early reproduce, since these structures are found inside the cell and thus called the endospore. They are extremely heat resistant and to the radiation. This primary resistant is due to the thick spore coat made up of deichoic acid.

### **a. Staining of cell wall**

As we have discuss the simple and differential stains which are mainly cell wall stains and they don't stain any other specific structure such as capsule, flagella, spore etc.

### **b. Endospore staining**

Prepare a heat fix smear of the given culture and place the slide on a staining rack above boiling water. Cover the smear with a small piece of paper and saturate with malachite green continue heating for about 5 minutes. Wash gently with water and counter stain with safranin for 30 seconds again wash with water and remove the excess of water with the help of blotting paper. Examine the preparation under oil immersion objective.

This kind of staining is done in case of *clostridium* and *bacillus*.

### **c. Capsule staining**

In many bacteria such as *Diplococcus pneumonia*, *Pseudomonas* etc, a viscous or gelatinous substance secreted by the surrounding of the cell wall called as a capsule.

### **Method**

Prepare smear of the bacterium is made on a glass slide and allow it for air dry (not heat fix) this smear add a drop of Congo red dye and allow it to air dry. Then the smear is fixed with the help of acid alcohol for 15 seconds and washed with water. Then the smear is flooded with fuchsin for one minute then the slide is again washed with water and remove the excess of water with the help of filter paper and examined the preparation under oil immersion objective. This results that the capsule appears colourless surrounding red cells against a dark blue background.

### 3. DIFFERENTIAL STAINING

In case of this type of staining, the differentiate two types of cells which are belonging to two bacterial species based on their staining characteristics. However a differential staining can also differentiate the different parts of the cell for instant endospores of flagella etc.

The most popularly known stains in case of differential staining are gram stain and acid fast stain since this help in differentiating between *gram positive* and *Gram Negative bacteria*.

#### a. Gram staining:

The gram stain is named after Christian gram, a microbiologist who has discovered it in 1884. This staining is particularly used in case of bacteria.

##### *Method of Gram staining*

To the heat fix smear add a drop of crystal violet solution, allow it for 1 minute and then wash with tap water, then drink of all the excess of water with the help of a blotting paper and then use iodine solution for 1 minute and again wash with tap water, decolourised with 95% of alcohol and now flood the slide with safranin for 1 minute and again wash with water and air dry, examine the preparation under microscope. usually the gram positive bacteria looks dark purple in colour since they take both stains such as crystal violet and basic fuchsin. While in case of gram negative bacteria look light red being stained only by safranin.

#### b. Acid fast stain

It was first developed by Paul Ehrlich in year 1882. The acid fast stain, stains only in case of *mycobacteria tuberculosis*, *bacilli* and some related *actinomycetes*. The main stain used in case of this type is carbolfuchsin which is usually made from basic fashion phenol, water and ethyl alcohol

##### *Method*

Method a non-pathogenic species of *mycobacterium* is usually used along with the non-acid fast bacterial, all the cells are stained. The glass slide is heated for about 3-4 minutes. A decolourising solution usually containing the sulphuric acid and ethanol is added. This helps in the removal of extra dye from all the cells except the acid fast bacteria. However the methylene blue is added as counter stain.



**UNIT-4: GENERAL ACCOUNT OF ACELLULAR ORGANISMS****VIRUSES**

The word virus (Latin word= a poisonous liquid) was used to denote all kinds of poisonous agents including snake poisons and till about 140 years ago

The inhabitants of microorganisms have lot of influence on human life. They are both friends as well as enemies of man. Among the most important of microbial enemies of human living beings, viruses occupy a prominent place. Simple and tiny to pass through the minute bacterial filters, yet potent enough to change the destiny of human life, viruses are today the centre of attention in causing one of the deadliest human diseases.

Adolf Meyer demonstrated the existence of virus. They are a cellular as they lack cellular organisation.

***Living characters of viruses***

- Viruses have genetic material DNA are
- They mutate.
- They can grow.
- They can be transmitted from one host to another.
- Capable of multiplication within a host.
- They react to heat, radiation and Chemicals.
- They show irritability.
- They bring about enzymatic changes *in vitro*.
- They are able to infect and cause diseases to living beings.
- The DNA and proteins of viruses are similar in composition and structure those of higher organisms.

***Non-living characteristics of viruses.***

- They can be crystallized like an ordinary chemical and stored in a bottle or test tube.
- Outside the host, viruses are inert (inactive).
- There is no cell wall, membrane or cytoplasm.
- Sedimentation of viruses is according to their molecular weight like non-living beings.

- They are not capable of any function, unless they obtained metabolic products from others.
- Energy production enzyme system is absent.

***Some unique characteristics of viruses (living and nonliving):***

- Presence of only DNA RNA.
- Capacity to produce from the nucleic acid.
- Do not show cell division.
- They use the metabolic machinery of the host cell to replicate.

Hence many biologists believe it is better to regard 'viruses as chemicals in a test tube but living are in inside the host'.

***Properties of viruses:***

- Viruses are called acellular as they do not have cellular organisation like other microorganisms.
- They are ultramicroscopic (invisible under ordinary microscope).
- Genetic material is either DNA or RNA but never both.
- They are obligate parasites.
- Viruses can pass through bacterial filters.
- Even though viruses are made up of nuclear proteins, they lack the enzymes necessary for the synthesis. For this they depend on host enzyme.
- Viruses do not show cell division.
- They can be crystallized.
- Virus proteins have high molecular weight.
- They can be transmitted from one host to another either directly or indirectly through vectors.
- The capsid (outer coat) of viruses is mostly made up of proteins except in some animal viruses where polysaccharides are also present.
- They can resist high temperature and they are also resistant to acids, alkalis and salts.
- They are capable of mutation.

**Classification of viruses**

*Earlier viruses were classified based on their hosts:*

- Animal virus- these infect animals.
- Plant viruses- these infect plants.
- Bacteriophages- these infect bacteria
- Phyco viruses- these infect algae.
- Mycoviruses- these infect fungi
- Mycoplasma viruses- these infect mycoplasma
- Cyanophages- infect cyanobacteria

Lowaff in 1966 proposed systematic classification according to which viruses are classified based on the following criteria:

1. Chemical nature of nucleic acid: RNA or DNA- single or double stranded.
2. Structure of capsule: helical, icosahedral, naked or enveloped.
3. Site of replication: nucleus or cytoplasm.
4. Host range: specific host tissue or cell types.
5. Mode of transmission: body fluids, feces, water etc.
6. Specific surface structures: antigenic properties.

Lowaff, Home and Toumier proposed the following system of classification; according to which the viruses are included under the Phyla- Vira which is divided into 2 sub phyla:

- *Subphylum- Deoxy-vira* (DNA virus)
- *Subphylum- ribovira* (RNA virus).

In other system of classification proposed by Layiens and King in 1975, viruses are classified based on the type of nucleic acid, presence or absence of an envelope and site of assembly of virus particles in the host.

*They have classified viruses into 4 divisions:*

- ssRNA viruses (single stranded RNA viruses)
- dsRNA viruses (double stranded RNA viruses)
- ssDNA viruses (single stranded DNA viruses)
- dsDNA viruses (double stranded DNA viruses)

## STRUCTURE OF VIRUSES

Viruses are acellular, hence they don't have cytoplasm, Cell wall and cell membrane. They are extremely small, smaller than the bacteria.

The technical name of virus particle is **Virion**. Virion varies in size. They range in size from small 20 nm of parvo virus to the 250 nm of Pox viruses may appear in several shapes. They may have rod shaped, Bullet shaped, oval and pleomorphic.

**Helix:** certain viruses are helix and are said to have helical symmetry. Their helix is a tightly wound coil resembling a cork screw or spring.

**Icosahedron:** it is a polyhedron with triangular faces and 12 corners.

**Complex:** these viruses have a combination of both helical and Icosahedral symmetry.

All the Viruses consist of two basic components, a core of nucleic acid called the *genome* and a surrounding coat of proteins known as a capsid. The genome contains either DNA or RNA, but not both the nucleic acids may be single stranded or double stranded which may be broken or unbroken.

The capsid protects the genome. It also gives regular symmetry to the virus. The capsid is subdivided into individual protein subunits called *capsomeres*. The capsid and genome is called *nucleo-capsid*.

### ❖ PLANT VIRUSES

Plant viruses are the viruses that infect Plants. Most of the plant viruses are RNA viruses, while only few plants contain the DNA for example Cauliflower Mosaic Virus (CaMV). In case of this, the structure of the DNA is double helical structure while the structure of the RNA may be either single stranded or double stranded RNA.

The earliest viruses to be identified and described are viruses infecting plants and one of the most thoroughly studied is Tobacco Mosaic Virus (TMV). Generally the plant viruses are either elongated or spherical in shape.

**TMV- TOBACCO MOSAIC VIRUS**

- The TMV is one of the most thoroughly studied viruses in case of plants.
- The TMV is a rod shaped helical virus.
- It is 300 Å long and around 15 - 17 nm in diameter.
- Structurally there is a single stranded RNA (ssRNA) helix with a helical protein sheath. T
- The virus weight is about  $38 \times 10^6$  Dalton's.
- According to the X-ray crystallographic study it shows that the protein sheath is made up of about 2,000 identical subunits and each subunit has a molecular weight of about 12 -15000. Generally the shapes of the subunits are ellipsoidal.
- The genetic material which is present in the centre which is made up of a single stranded RNA molecule with a molecule weight of about 2.1 million. The pitch of The Helix is about 23 Å while the radius is 39 Å.

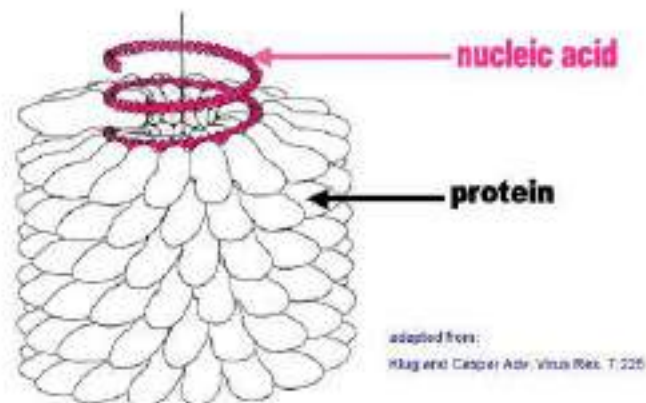
**TOBACCO MOSAIC VIRUS****CaMV- CAULIFLOWER MOSAIC VIRUS**

- The cauliflower mosaic virus was the first plant virus to show the presence of the DNA molecule instead of RNA.
- CaMV infects Cauliflower plants.
- CaMV is an icosahedral virus about 24 nm in diameter.
- It has about 10 to 12% double stranded DNA and rest of the proteins and amino acids.

- Its protein shell is made up of 180 protein subunits and clustered into groups of 5 (pentameres) and 6 (hexameres).
- The diameter is 25-30 nm.
- Weight is  $5.6 \times 10^8$  daltons.

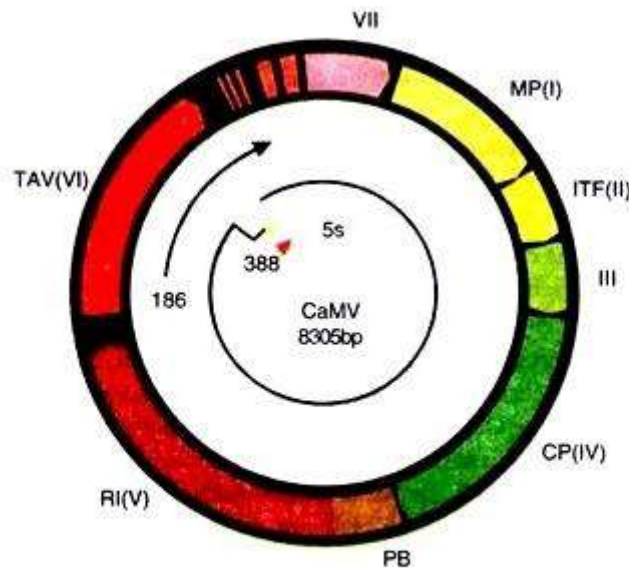

Open circular, double stranded DNA showing seven ORFs. The genome contains discontinuities in both strands, one in the transcribed strand and 1 to 3 in the non-transcribed strand

### ❖ ANIMAL VIRUSES

the viruses that infect animals are called animal virus, once they are infected to animal they shows a variety in their structure and the host range however there is a considerable range size of viruses. But most of the viruses fall in the size range between 10 and 200 nm. while some like yellow fever foot and mouth disease are small in diameter of about 25 nm where size in others like Pox virus are large about 230 nm in diameter, however except these large viruses, while most of the others are invisible.

In other outward form i.e., shape of viruses will also differ from one virus to other. Generally they may be rod shape, spherical to oval or Bullet shaped.

In general majority of the animal virus possesses a membranous envelope outer to the protein coat which encloses the genetic material (nucleic acids). The virus membrane mainly consists of the fats and glycoproteins and which play an important role in recognising in host cell surface during infection and the genetic material made of either RNA or DNA.

Some of the examples of DNA viruses are small pox viruses, Pox virus has come up herpes virus and hepatitis B virus.

### HEPATITIS- B VIRUS

- The Hepatitis-B causes a disease called as the serum hepatitis.
- Can be transmitted by sexual contact or even from the mother to the Infant during the child birth.
- The disease can also be caused by saliva which is the other means of transfer of the virus.
- The period of Hepatitis-B is around 100-200 days.
- The virus is more dangerous than the HIV virus and this Hepatitis-B also leads to death.
- Hepatitis-B belongs to the family Hepadnaviridae.
- Genetic material is DNA.
- The genetic engineering process has also used for the synthesis of vaccine for Hepatitis-B.
- The vaccine is marketed by different companies as recombivax.
- Preservation is through vaccination.

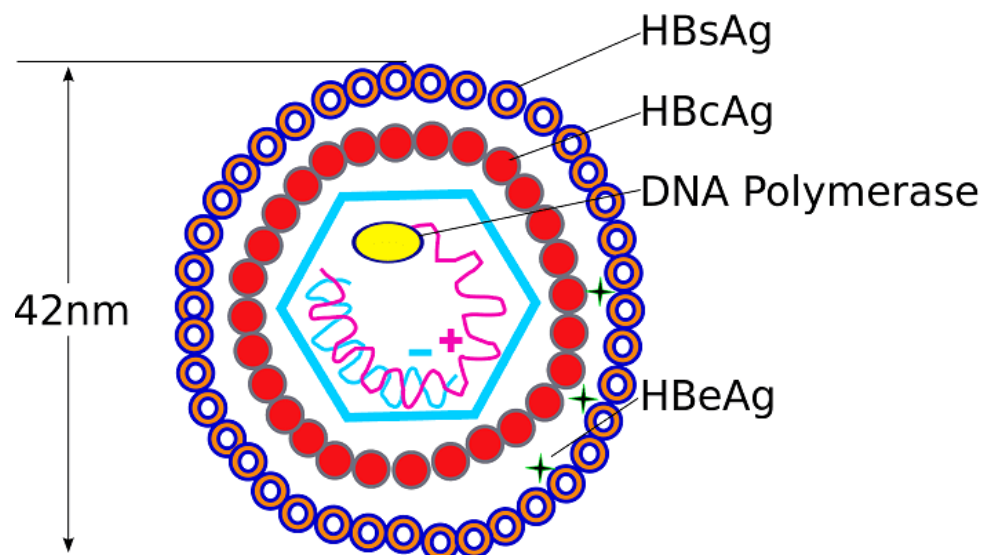

**HIV- HUMAN IMMUNODEFICIENCY VIRUS**

- HIV belongs to the lentivirus which is subgroup of retroviridae.
- The virus has a spherical envelope and it is about 90-115 nm in size.
- This causes acquired immunodeficiency syndrome (AIDS), a condition in humans in which progressive failure of immune system.
- Classification:
  - Family: Retroviridae
  - Subfamily: Orthoretrovirinae
  - Genus: lentivirus
  - Species: HIV 1/ HIV 2
- Very high genetic variability.
- Composed of two copies of positive single stranded RNA conical capsid composed of viral protein P24.
- The RNA genome consists of 9 genes.
- Inside of capsid are three enzymes required for HIV replication: reverse transcriptase, integrase and protease.
- Matrix is surrounded by phospholipids.
- HIV doesn't survive well outside the body.
- May survive upto 7 days in dry blood.
- Virus is inactivated under extreme changes of pH in acidic and alkaline medium.

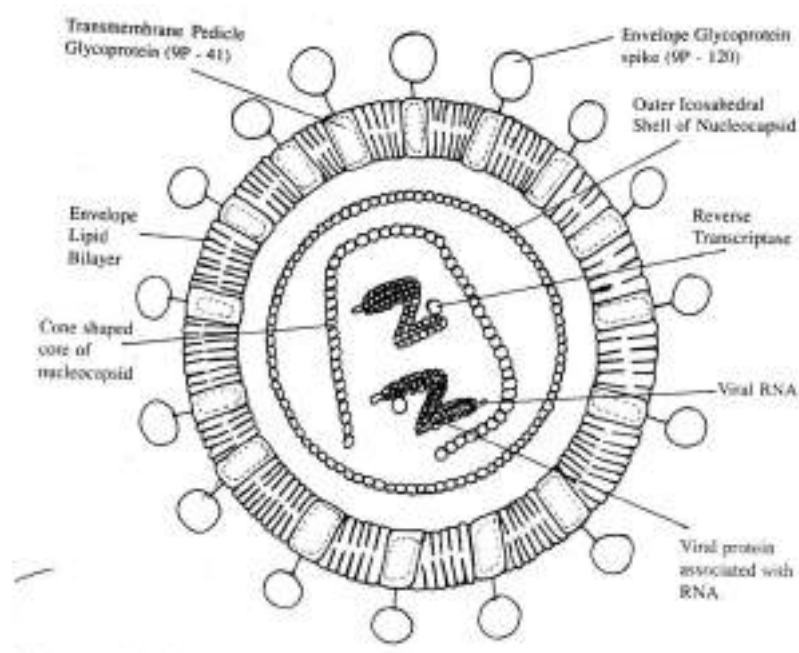



### ❖ BACTERIOPHAGES

Bacteriophages or bacterial viruses are the viruses that infect bacteria and cause disease. These have great importance today in the study of microbial genetics and molecular biology. The bacteriophages are very large in size. This was discovered by Twort in 1915 and later studied by Herelle in 1977.

### LAMBDA PHAGE

- Lambda phage is a bacterial virus, or bacteriophage, that infects the bacterial species *E. coli*.
- The lambda phage DNA is a linear and double stranded and at ends are single stranded which are complementary to each other.
- This produces repressor protein which resist lysis of cell.
- This virus is a temperate phage.
- It consists of lytic and lysogenic pathways.
- It comprises of head, neck and tail.
- The sticky ends are complementary to each other.
- When the linear DNA enclosed a protein body.
- Belongs to Siphoviridae family.
- Nearly 50 nm diameter.
- Icosahedral head.
- A flexible tubular protein tail.
- Connector serves as a site for attachment of performed head to tail.
- It is a temperate phage.
- Contains large genome.

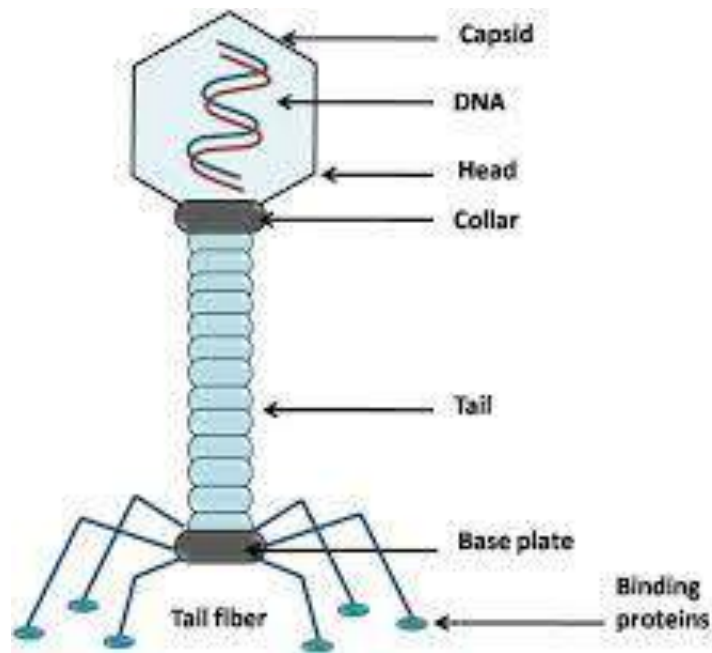

## T4 PHAGE

- T4 is a bacteriophage that infects *E. coli* bacteria.
- T4 is among the largest phages.
- Complete genome sequence is 169-170 kbp long.
- About 80-100 nm wide.
- Contains head, collar and tail.
- Encodes about 300 genes.
- T4 biology and its genomic sequence provide the best- understood model for modern functional genomics and proteomics.
- Its tail fibres allow attachment to a host cell.
- The T4 tail is hollow so that it can pass its nucleic acid to the cell it is infecting during attachment.

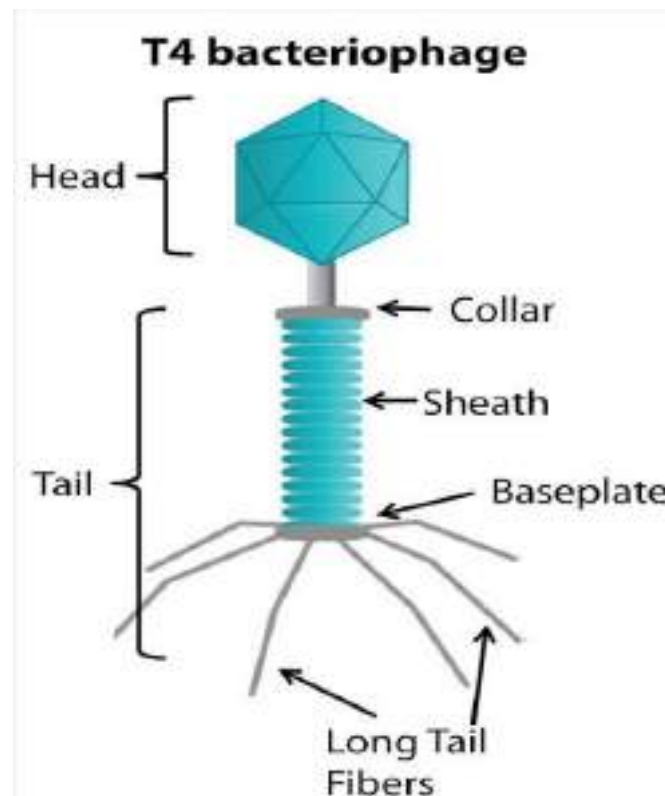

## VIROID

Viriods are the smallest infectious pathogens known. They are solely composed of a short strand of circular, single-stranded. RNA without protein coat. All known viriods are inhabitants of higher plants, in which most cause diseases, some of which are of slight to catastrophic economic importance.

The first recognized viroid, the pathogenic agent of the potato spindle tuber disease, was discovered, initially molecularly characterized and named by Theodor otto Diener, plant pathologist at the U.S. Department of Agriculture's Research Centre in Beltsville, Maryland 1971. This viroid is now called Poato Spindle Tuber Viriod, abbreviated PSTVD. Although viriods are composed of nucleic acid, they do not code for any protein.

## POTATO SPINDLE TUBER VIROID- PSTV

- This was the first viroid to be identified.
- PSTV is a small, circular RNA molecule.
- All potatoes and tomatoes are susceptible to PSTV and there is no form of natural resistance.
- Prions are misfolded proteins.

- Symptoms range from mild to severe.
- Mild strains produce no obvious symptoms.
- Symptoms in severe strains are dependent on environmental conditions and are most severe in hot conditions.
- Symptoms may be mild in initial infections but become progressively worse.
- Transmission through aphids and also mechanical transmissions.

### **PRIONS**

- Prions were first discovered by Stanley B. Prusiner and his associates.
- According to them, prions are tiny organisations made entirely of proteins and contain no gene material of their own.
- Prions are 100-1000 times smaller than the smallest organisations.
- According to the reports these can survive heat, radiation and chemical treatments that normally destroy viruses.
- The infection effect of prions on the host varies from acute, chronic, persistent, latent and slow progressive tumor producing influence.
- These are capable of infecting even in the absence of nucleic acids.
- The mechanism of replication is still unknown.
- Prions have been implicated in the disease 'scrap' which is a fatal disease of nervous system of sheep.
- Prions have also been implicated in disease such as senile dementia, multiple sclerosis etc.
- Prions are an infectious agent composed entirely of protein material.
- Prion aggregates are extremely stable and accumulate in infected tissue, causing tissue damage and cell death.
- These are resistant to denaturation by physical and chemical agents.

### **CJD- CREUTZFELDT- JAKOB DISEASE**

- CJD is an incurable and universally fatal neurodegenerative disease.
- CJD is also called a human form of mad cow disease (Bovine Spongiform Encephalopathy or BSE).
- CJD is caused by a transmissible agent called Prion.
- Inherited type of transmission.

- CJD causes the brain tissue to degenerate rapidly and as the disease destroys the brain, the brain develops holes and the textures changes to resemble that of kitchen sponge.

#### *Types of CJD*

- Variant CJD (vCJD) caused by consuming food contaminated with prions.
- Sporadic (sCJD), caused by a mutation arising in an individual. This accounts for 85% of cases of CJD.
- Familial (fCJD), caused by an inherited mutation. This accounts for majority of the other 15% cases of CJD.
- Medical procedures that are associated with the spread of this form includes blood transfusion from the infected person, use of human derived pituitary growth hormones, gonadotropin hormone therapy etc.

#### **KURU**

- It is a very rare, incurable neurodegenerative disorder.
- Prevalent among the fore people of Papua New Guinea in 1950s and 60s.
- Kuru is a form of transmissible spongiform encephalopathy (TSE) caused by prion proteins.
- The term 'Kuru' derives from the fore word 'Kurua' or 'Guria' (to shake) due to the body tremors that are a classic symptoms of the disease and kuru itself means 'trembling'.
- The disease is more prevalent among women and child.
- Symptoms include body tremors, random outbursts of laughter, gradual loss of co-ordination.
- Complications include infection and pneumonia during the terminal stage.
- Risk factor may be coming into close contact with the brain of an infected individual.
- Diagnostic method is by the neurological examination.

**BSE- BOVINE SPONGIFORM ENCEPHALOPATHY**

- BSE commonly known as Mad Cow Disease, is a fatal neurodegenerative disease (encephalopathy) in cattle that cause spongiform degeneration of brain and spinal cord.
- BSE has a long incubation period of 2.5 to 5 years.
- Signs are not seen immediately in cattle's, due to extreme long incubation period.
- BSE is caused by a misfolded protein- a prion.
- Symptoms include abnormal behavior, trouble walking and weight loss, hyper-responsiveness; later the cow becomes unable to move finally death.
- Cattles are believed to have been infected from being fed meat and bone meal.
- Diagnostic method may be suspected based on the symptoms, confirmed by examination of the brain.
- Cases are classified as classic or atypical types.
- These can replicate.
- In the United Kingdom, the country worst affected by an epidemic in 1986-1998, more than 1,80,000 cattle were infected and 4.4 million slaughtered during the eradication program.
- The disease may be transmitted to humans by eating food contaminated with the brain, spinal cord or digestive tract of infected carcasses.

## EUKARYOTIC MICROORGANISMS

Eukaryotes are organisms whose bodies are made up of eukaryotic cells, such as protists, fungi, plants and animals. Eukaryotic cells are cells that contain a nucleus and organelles, and are enclosed by a plasma membrane. Organisms with eukaryotic cells are grouped into the biological domain Eukaryota (also sometimes called Eukarya). The other two domains of life, Archaea and Bacteria, have prokaryotic cells, which are simpler and lack organelles except for ribosomes, which make proteins.

### Types of Eukaryotes

There are four types of eukaryotes: animals, plants, fungi, and protists. Protists are a group of organisms defined as being eukaryotic but not animals, plants, or fungi; this group includes protozoa, slime molds, and some algae. Protists and fungi are usually unicellular, while animals and plants are multicellular. Unicellular eukaryotes can reproduce sexually or asexually. They move with the use of flagella, which are small thread-like appendages that extend from the cell membrane. Unicellular eukaryotes perform many of the same actions as multicellular eukaryotes, such as locomotion, respiration, digestion, excretion, and reproduction.

### *Fungi*

A fungus (plural: fungi) is any member of the group of eukaryotic organisms that includes microorganisms such as yeasts and molds, as well as the more familiar mushrooms. These organisms are classified as a kingdom, which is separate from the other eukaryotic life kingdoms of plants and animals.

Characteristics of Fungi

1. Fungi is a separate kingdom, Fungi are Eukaryotic organism
2. More than 2,00,000 fungi species are known
3. Morphology:
  - The plant body of true fungi (Eumycota), the plant body is a thallus.
  - It may be non-mycelial or mycelial. The non-mycelial forms are unicellular; however, they may form a pseudomycelium by budding. In mycelial forms, the plant body is made up of thread like structures called hyphae
  - Fungi exists in two fundamental forms, filamentous or hyphal form (MOLD) and single celled or budding form (YEAST).

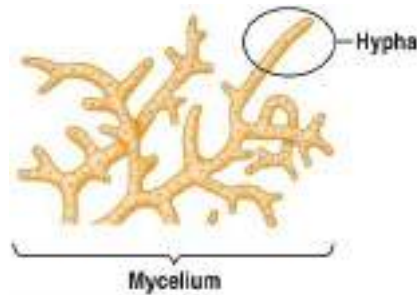

- But for the classification of fungi, they are studied as mold, yeast, yeast like fungi and dimorphic fungi.
  - Yeast is Unicellular while Mold is multicellular and filamentous
4. Fungi lacks Chloroplast.
  5. Mode of nutrition:
    - Fungi are organotrophic heterotrophs.
    - Mostly Fungi are saprophytic and some are Parasitic
  6. Fungi grow best in acidic environment (tolerate acidic pH).
  7. Fungi can tolerate high sugar concentration and dry condition
  8. Most of the fungi are Obligate aerobes (molds) and few are facultative anaerobes (yeasts)
  9. Optimum temperature of growth for most saprophytic fungi is 20-30 C while (30-37) C for parasitic fungi.
  10. Growth rate of fungi is slower than that of bacteria.
  11. Cell wall is composed of chitin
  12. Cell membrane consists of ergosterol
  13. Reproduction: both asexual (Axamorph) and sexual (Teliomorph) mode of reproduction
    - Asexual methods: fragmentation, fomatic budding, fission, asexual spore formation
    - Sexual methods: gametic copulation, gamete-gametangium opulation, gametangium copulation, somatic copulation and Spermatization.
  14. More than 100 fungi are responsible for human infection.
  15. Some fungi shows mutualistic relationship with higher plants, eg Mycorrhiza is symbiotic associated with root of gymnosperm



### Classification of fungi

#### Phycomycetes

- Members of phycomycetes are found in aquatic habitats and on decaying wood in moist and damp places or as obligate parasites on plants.
- The mycelium is aseptate and coenocytic, Asexual reproduction takes place by zoospores (motile) or by aplanospores (non-motile).
- These spores are endogeneously produced in sporangium.
- Zygosporangia are formed by fusion of two gametes
- Examples: Mucor, Rhizopus and Albugo (the parasitic fungi on mustard).

#### Ascomycetes:

- Sexual spore produced within a sac like structure called ascus.
- Sexual spores are called ascospores
- Asexual reproduction occurs by single celled or multi celled conidia
- Ascomycetes are also known as sac fungi.
- Hyphae are generally septated
- Examples: *Saccharomyces*, *Arthroderma*, *Gibberella*

#### Basidiomycetes:

- Sexual spores are produced externally on a basidium
- Sexual spores are known as basidiospores
- Asexual reproduction occurs by budding, fragmentation or conidia formation
- They are commonly called as mushroom group
- Hyphae are generally septated
- Examples: *Amanita*, *Agaricus*, *Filobasidiella*

#### Zygomycetes:

- Sexual spores are known as Zygosporangia
- Zygosporangia are formed by fusion of two similar cells.
- Asexual reproduction occurs by sporangiospores
- Hyphae are generally aseptate.
- Examples: Rhizopus, Mucor, Basidiobolus, Conidiobolus

#### Deuteromycetes:

- No sexual stage is present
- Deuteromycetes are also known as fungi imperfecti.

- Asexual reproduction occurs by means of conidia.
- Most of the human and animal pathogens are present in this class.
- Examples: *Candida*, *Cryptococcus*, *Trichophyton*, *Epidermophyton*, *Histoplasma*

### Reproduction

The fungi either reproduces vegetatively, asexually or sexually:

- Vegetative Reproduction

- Fragmentation: Some forms belonging to Ascomycotina and Basidiomycotina multiply by breakage of the mycelium.
- Budding: Some unicelled forms multiply by budding. A bud arises as a papilla on the parent cell and then after its enlargement separates into a completely independent entity.

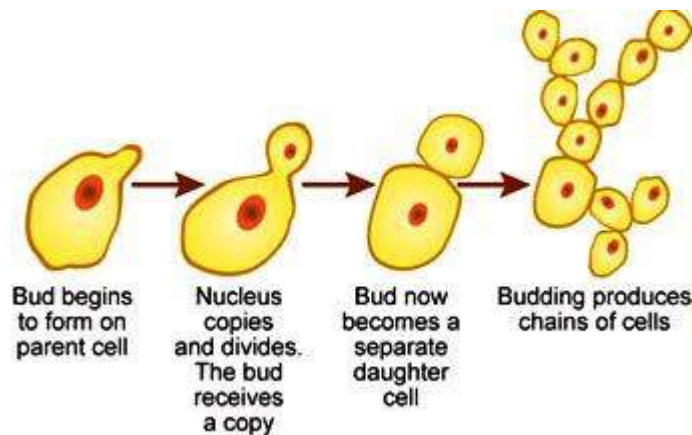

- Fission: A few unicelled forms like yeasts and slime moulds multiply by this process.
- Asexual Reproduction
  - Sporangiospores: These are thin-walled, non-motile spores formed in a sporangium. They may be uni- or multinucleate. On account of their structure, they are also called as aplanospores.
  - Zoospores: They are thin-walled, motile spores formed in a zoosporangium.
  - Conidia: In some fungi, the spores are not formed inside a sporangium. They are born freely on the tips of special branches called conidiophores. Thus, these spores are conidia.

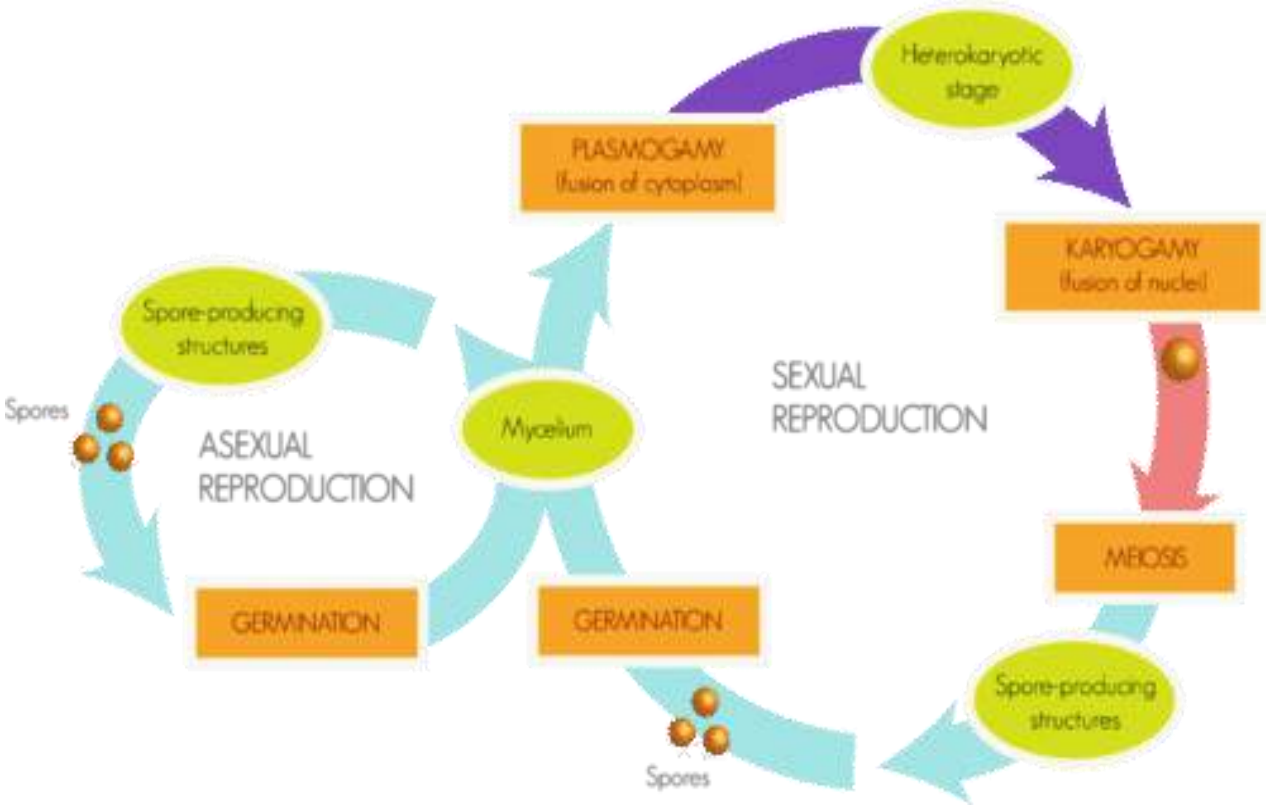
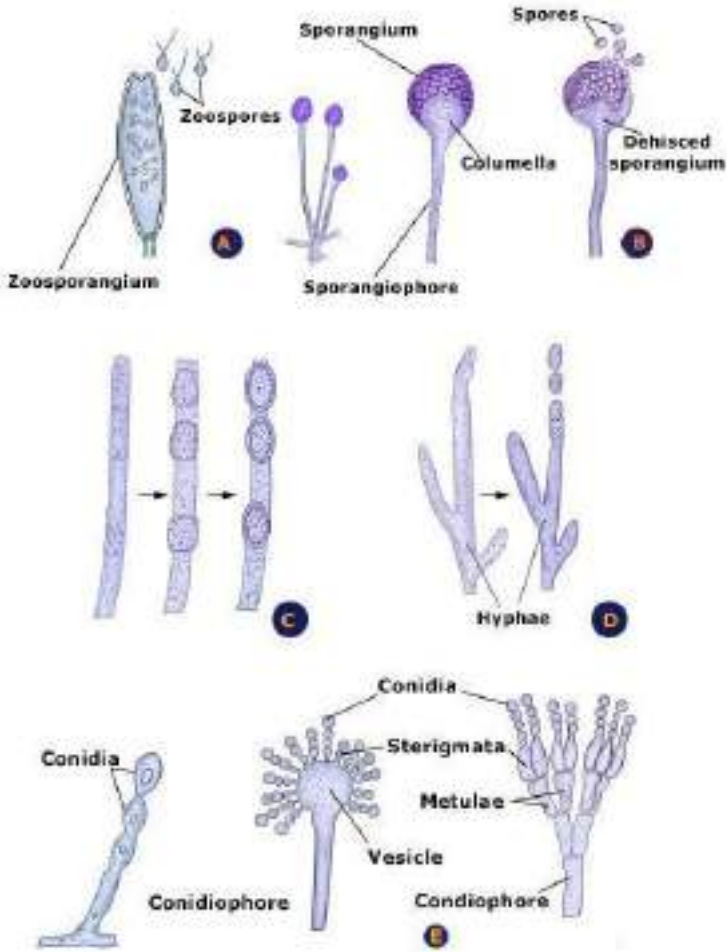

- Sexual reproduction: With the exception of Deuteromycotina (Fungi imperfecti), we find sexual reproduction in all groups of fungi. During sexual reproduction, the compatible nuclei show a specific behaviour which is responsible for the onset of three distinct mycelial phases. The three phases of nuclear behaviour are as under:
  - Plasmogamy: Fusion of two protoplasts.
  - Karyogamy: Fusion of two nuclei.
  - Meiosis: The reduction division.

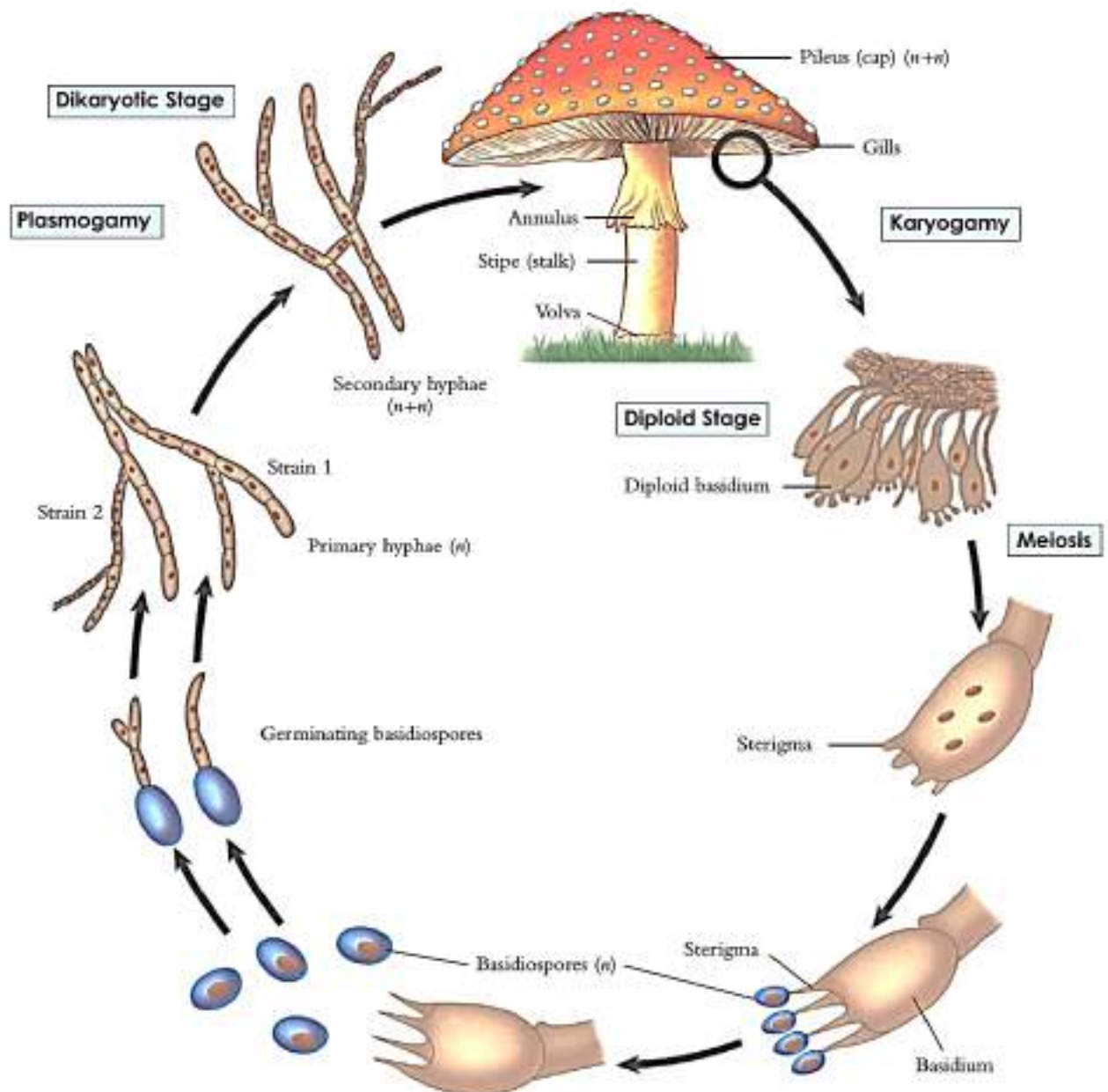

## Economic Importance Of Fungi

Fungi are an important organism in human life. They play an important role in medicine yielding antibiotics, in agriculture by maintaining soil fertility, are an important means of food, and forms the basis of many industries. Let us have a look at some of the fields where fungi are really important.

### **Importance in Human Life**

Fungi are very important to humans at many levels. They are an important part of the nutrient cycle in the ecosystem. They also act as pesticides.

### **Biological Insecticides**

Fungi are animal pathogens. Thus they help in controlling the population of pests. These fungi do not infect plants and animals. They attack specifically to some insects. The fungus *Beauveria bassiana* is a pesticide that is being tested to control the spread of emerald ash borer.

### **Reusing**

These microbes along with bacteria bring about recycling of matter by decomposing dead matter of plants and excreta of animals in the soil, hence the reuse enriches the soil to make it fertile. The absence of activities of fungi can have an adverse effect on this on-going process by continuous assembly and piling of debris.

### **Importance in Medicine**

- Metabolites of fungi are of great commercial importance.
- Antibiotics are the substances produced by fungi, useful for the treatment of diseases caused by pathogens. Antibiotics produced by actinomycetes and moulds inhibits the growth of other microbes.
- Apart from curing diseases, antibiotics are also used fed to animals for speedy growth and to improve meat quality. Antibiotics are used to preserve freshly produced meat for longer durations.

- Penicillin is a widely used antibiotic, lethal for the survival of microbes. The reason it is extensively used is since it has no effect on human cells but kills gram-positive bacteria.
- Streptomycin, another antibiotic is of great medicinal value. It is more powerful than Penicillin as it destroys gram-negative entities.
- Yield-soluble antibiotics are used to check the growth of yeasts and bacteria and in treating plant diseases.
- Administration of Griseofulvin results in the absorption by keratinized tissues and are used to treat fungal skin diseases (ringworms).
- Ergot is used in the medicine and the vet industry. It is also used to control bleeding post-child-birth.
- LSD – Lysergic acid, is a derivative of ergot and is used in the field of psychiatry.
- Consuming fungi called Clavatia prevents cancer of the stomach.

### Importance in Agriculture

The fungi plant dynamic is essential in productivity of crops. Fungal activity in farmlands contributes to the growth of plants by about 70%.

Fungi are important in the process of humus formation as it brings about the degeneration of the plant and animal matter.

They are successively used in biological control of pests. Plant pests are used as insecticides to control activities of insects. For example – *Empausa sepulchralis*, *Cordyceps melonhae*.

Use of fungal pesticides can reduce environmental hazards by a great extent.

Fungi are also used in agricultural research. Some species of fungi are used in the detection of certain elements such as Copper and Arsenic in soil and in the production of enzymes. For instance, biological and genetic research on fungi named Neurospora led to the One Gene One Enzyme hypothesis.

The fungi live in a symbiotic relationship with the plant roots known as mycorrhiza. These are essential to enhance the productivity of farmland. 80-90% of trees could not survive without the fungal partner in the root system.

## Importance in Food industry

Some fungi are used in food processing while some are directly consumed. For example – Mushrooms, which are rich in proteins and minerals and low in fat.

Fungi constitute the basis in the baking and brewing industry. They bring about fermentation of sugar by an enzyme called zymase producing alcohol which is used to make wine.

Carbon dioxide- a by-product in the process, is used as dry ice and also in the baking industry to make the dough (rising and lightening of dough).

*Saccharomyces cerevisiae* is an important ingredient in bread, a staple food of humans for several years. It is also known as the baker's yeast.

## Algae

The term "algae" covers many different organisms capable of producing oxygen through photosynthesis (the process of harvesting light energy from the sun to generate carbohydrates). These organisms are not necessarily closely related. However, certain features unite them, while distinguishing them from the other major group of photosynthetic organisms: the land plants.

### GENERAL CHARACTERISTICS OF ALGAE

1. Algae are the simplest multicellular plants. Some are unicellular eg. *Chlamydomonas*
2. Plant body: known as Thallus and they are avascular
3. Habitat: Algae are usually aquatic, either freshwater or marine and some are terrestrial.
4. Algae are eukaryotic thallophytes.
5. Algae are photoautotrophs.
6. Storage form of food: Starch
7. Reproduction: Algae reproduce either by vegetative, asexual or sexual method
8. Vegetative method: fragmentation, hormogonia
9. Asexual spore: zoospores, aplanospores, hypnospores, akinet

## CLASSIFICATION OF ALGAE

On the basis of photosynthetic pigments algae classified into three classes.

1. Chlorophyceae (green algae)
2. Phaeophyceae (brown algae)
3. Rhodophyceae (red algae).

### 1. Chlorophyceae (Green algae)

General characteristics of Chlorophyceae

- It is the largest class of algae
- They are commonly known as green Algae.
- Photosynthetic pigments: They possess chlorophyll a, chlorophyll b and small amount of  $\beta$ -carotenoids.
- The chloroplasts show various shapes i.e. spiral shape in *Spirogyra*, cup shaped in *Chlamydomonas*, star shaped in *Zygnema*, girdle shaped in *Ulothrix*
- Habitat: Mostly freshwater (*Spirogyra*, *Oedogonium*, *Chlamydomonas*, *Volvox*, etc), some are marine (*Sargassum*, *Laminaria*, etc) and some are parasitic (*Polysiphonia*, *Harvevella*, *Cephaleuros*)
- Distribution: they are cosmopolitan in distribution
- They are unicellular as well as multicellular.
- Each cell is eukaryotic
- Thallus: their body structure, shape and size varies.
- Examples: *Chlamydomonas*: unicellular free living
- *Volvox*: colonial form
- *Spirogyra*: multicellular, unbranched filamentous form
- *Ulva*: multicellular, parenchymatous form
- Storage form of food: Starch
- Pyrenoids store starch
- Cell wall has two layers: outer layer composed of pectose and inner layer is composed of cellulose
- Reproduction: vegetative, asexual and sexual method
- Vegetative : fragmentation
- Asexual: asexual spores (akinetes, aplanospores, azygospores)



- Sexual: isogamous, anisogamous, oogamous type gametic fusion

## 2. Phaeophyceae (Brown algae)

### General characteristics of Phaeophyceae

- Phaeophyceae are commonly known as brown algae
- Photosynthetic pigments: They possess brown colored photosynthetic pigments fucoxanthin and  $\beta$ -carotenoids in addition to chlorophyll a and c.
- Habitat: They are almost marine, very few are fresh water eg.
- Thallus: they are multicellular brown algae. No unicellular and colonial (motile or non-motile) brown algae till known.
- Storage form of food: laminarin starch, manitol (alcohol) and some store iodine also.
- Reproduction: vegetative, asexual and sexual methods
- Vegetative: fragmentation.
- Asexual: asexual spores (motile zoospores).
- Sexual: isogamous or oogamous type gametic fusion.

## 3. Rhodophyceae (Red algae)

### General characteristics of Rhodophyceae

- Rhodophyceae are commonly known as Red Algae
- Photosynthetic pigments: They possess red colored photosynthetic pigments r-phycoerythrin and r-phycoerythrin along with chlorophyll a, d, xanthophyll and  $\beta$ -carotenoid
- Habitat: They are aquatic, mostly marine. Some are freshwater e.g. *Batrachospermum*.
- Thallus: Red algae show a variety of life forms-
- Examples: Unicellular- *Porphyridium*,
- multicellular- *Goniotrichum*,
- Parenchymatous- *Porphyra*,
- unicellular colonies-*Chrootheca*,
- Storage form of food: Floridean starch and floridosides sugar.
- Reproduction: vegetative, asexual and sexual mode
- Vegetative: fragmentation
- Asexual reproduction: non- motile spores( akinete, aplanospore, azygospore)

- sexual reproduction: Oogamous.
- Some species shows Alternation of generations in their life cycle.

### Reproduction

**The modes are: 1. Vegetative 2. Asexual 3. Sexual.**

#### **Mode # 1. Vegetative Reproduction:**

In this type, any vegetative part of the thallus develops into new individual. It does not involve any spore formation and there is no alternation of generations. It is the most common method of reproduction in algae.

#### **Mode # 2. Asexual Reproduction:**

Asexual reproduction involves the formation of certain type of spores — either naked or newly walled. It is a process of rejuvenation of the protoplast without any sexual fusion. Each and every spore germinates into a new plant. In this method, there is no alternation of generations.

#### **Mode # 3. Sexual Reproduction:**

All algae except the members of the class Cyanophyceae reproduce sexually. During sexual reproduction gametes fuse to form zygote (Fig. 3.18). The new genetic set up can develop by the fusion of gametes coming from the different parents.

#### **Economic Importance of Algae**

1. Algae Constitute the Link of Food Chain
2. Algae is Useful in Fish Culture
3. Algae is Used for Recreational Purposes
4. Algae is Useful in Sewage Treatment Plants
5. Algae and Water Supplies
6. Algae as the Origin of Petroleum and Gas
7. Algae and Limestone Formation
8. Algae is Used in Space Research and Other Fundamental Studies
9. Algae is Used as Food
10. Algae is Used as Fodder
11. Algae is Used as Fertilizers
12. Algae is Used as Medicine
13. Industrial Utilization of Algae

## Protozoa

- term Protozoa (From Greek, **protos** meaning **first**, **zoon** meaning **animals**) was given by **Goldfuss**.
- According to five-kingdom classification system, protozoans belong to the phylum Protozoa of kingdom **Protista**.

### General characteristics:

- The protozoans are minute, generally microscopic and eukaryotic organisms.
- They are the simplest and primitive of all the animals with very simple body organization, i.e. **Protoplasmic grade** of organization.
- They are **unicellular** organisms without tissues and organs.

#### 1. Habit and habitat:

- They may either be **free-living** (inhabiting fresh water, salt water or damp places) or **parasitic** (living as ecto- or endoparasites). Some are **commensals** in habit.
- Body is either naked or covered by a **pellicle** (plasmalemma or theca or lorica).
- Protozoans are either **solitary** or **colonial**; in colonial forms, the individuals are alike and independent.

#### 2. Cell structure:

- Body shape is variable; it may be spherical, oval, elongated or flattened.
- They are usually **asymmetrical** but *Giardia* is **bilaterally symmetrical**.
- The protoplasm is differentiated into outer **ectoplasm** and inner **endoplasm**.
- They may have one or more nuclei. Nucleus may be **monomorphic** or **dimorphic, vesicular** (e.g. *Entamoeba*) or massive (e.g. *Amoeba*).
- Vesicular nucleus is commonly spherical, oval or biconvex.
- Dimorphic nuclei are found in **Ciliata**, one larger **macronucleus** (with **trophochromatin**) and other small **micronucleus** (with **idiochromatin**).
- Locomotory organelles are either **pseudopodia, flagella, cilia** or none.

#### 3. Life processes:

- There is **no physiological division of labor** and all the vital activities of life are performed by a single cell.

- Nutrition may be **holozoic** (animal like), **holophytic** (plant like) **sporozoic** or **parasitic**.

\*In *Euglena*, the mode of nutrition is mixotrophic (both holozoic and holophytic).

- Digestion takes place inside the food vacuoles, i.e. **intracellular**.
- Respiration and occurs by **diffusion** through general body surface.
- Excretion occurs through general body surface like respiration. They are **ammonotelic** (excrete nitrogenous waste product in the form of ammonia).
- In some forms, egestion occurs through a temporary opening in the ectoplasm or through permanent opening called **Cytopyge**.
- **Contractile vacuoles** perform **osmoregulation** in fresh water forms and also help in removing excretory products.

\*Contractile vacuole is absent in marine and parasitic forms.

#### 4. **Reproduction:**

- Reproduction is either sexual or asexual; **asexual binary reproduction** occurs by **fission, multiple fission, budding** or **sporulation** and **sexual reproduction** occurs by **gamete formation** or **conjugation**.
- Binary fission may be simple or transverse or longitudinal or oblique.
- Life cycle often exhibits alternation of generation, i.e. it includes asexual and sexual phases.
- **Encystment** usually occurs to protect the cell from the **unfavorable conditions** and it also helps in dispersal.

### **Classification**

On the basis of locomotory organelles, phylum Protozoa has been divided into the following four classes.

#### **Class: Flagellata or Mastigophora**

- Usually free living but few are parasitic forms.
- One or more **flagella** usually present for locomotion or food capturing or attachment or protection.
- Body is covered with a pellicle which provides a definite shape.
- Some forms are green due to the presence of **chloroplasts** (e.g. *Euglena*).
- Asexual reproduction occurs by longitudinal binary fission.
- Single nucleus present in a cell.
- e.g. *Volvox*, *Noctiluca*, *Trichomonas*, *Trypanosoma*, *Giardia*, *Leishmania* etc.

**Class: Rhizopoda or Sarcodina**

- Free living or endoparasite.
- Contractile vacuole may be present or absent.
- Locomotory organelles are pseudopodia which also help in food capturing.
- Body is without a pellicle, and has no fixed shape.
- Protoplasm is differentiated into ectoplasm and endoplasm.
- Single nucleus is found in the endoplasm.
- Nutrition is holozoic and parasitic in few forms.
- Reproduction takes place by fission
- e.g. *Amoeba*, *Entamoeba* etc.

**Class: Spoprozoa**

- They are exclusively **endoparasites**.
- Locomotory organelles are **absent**.
- Body is covered by a thick pellicle.
- Nutrition is **saprophytic** and contractile vacuole is **absent**.
- Sexual reproduction takes place by **gamete** or **spore formation**.
- e.g. *Monocystis*, *Plasmodium* etc.

**Class: Ciliata**

- They may be either free living or **endoparasite**.
- Nucleus may be one, two or many in number.
- Body organization is complex.
- Body shape and size is definite and is covered with a pellicle.
- **Cilia** are the locomotory organelles.
- They have a holozoic mode of nutrition.
- Small **micronucleus** is **reproductive** in function whereas large **macronucleus** is **vegetative** in function.
- Asexual reproduction occurs by transverse fission and sexual by **conjugation**.
- e.g. *Opalina*, *Nyctotherus*, *Balantidium*, *Paramecium* etc.
-

### Economic importance

The protozoa are useful in the following ways:

#### 1. Food

Protozoa provide food for insect larvae, crustaceans and worms, which are taken by large animals like fishes, lobsters, clams, and crabs, which are eaten by man. Thus they form sources of food supply to man both directly and indirectly.

#### 2. Symbiotic Protozoa

Certain protozoa like *Trichonympha* and *Colonympha* etc. live in the gut of termites which help in the digestion of cellulose. The digested cellulose is utilized by the host.

#### 3. Insect Control

Several protozoa control harmful insects by persisting their bodies.

#### 4. Helpful in Sanitation

A large number of protozoa living in polluted water feed upon waste organic matters and thus purify it.

Many protozoa feed upon bacteria and play important role in the sanitary betterment and keeping water safe for drinking (Kudo, 1947).

#### 5. Industry

The skeletal deposits of marine protozoa (Foraminifera and Radiolaria) form oceanic ooze at the sea-bottom. About 30% of oceanic bed is covered with the *Globigerina* ooze, these skeletal deposits are put to many uses. Some are employed as filtering agents, others are made into chalk and still others are used for abrasives.

## PROKARYOTES

**Prokaryote**, also spelled **procaryote**, any organism that lacks a distinct nucleus and other organelles due to the absence of internal membranes. Bacteria are among the best-known prokaryotic organisms. The lack of internal membranes in prokaryotes distinguishes them from eukaryotes. The prokaryotic cell membrane is made up of phospholipids and constitutes the cell's primary osmotic barrier. The cytoplasm contains ribosomes, which carry out protein synthesis, and a double-stranded deoxyribonucleic acid (DNA) chromosome, which is usually circular

### **Characteristics of Prokaryotic Cell**

Prokaryotic cells have different characteristic features. The characteristics of the prokaryotic cells are mentioned below.

1. They lack a nuclear membrane.
2. Mitochondria, Golgi bodies, chloroplast, and lysosomes are absent.
3. The genetic material is present on a single chromosome.
4. The histone proteins, the important constituents of eukaryotic chromosomes, are lacking in them.
5. The cell wall is made up of carbohydrates and amino acids.
6. The plasma membrane acts as the mitochondrial membrane carrying respiratory enzymes.
7. They divide asexually by binary fission. The sexual mode of reproduction involves recombination.

### **Prokaryotic Cell Structure**

A prokaryotic cell does not have a nuclear membrane. However, the genetic material is present in a region in the cytoplasm known as the nucleoid. They may be spherical, rod-shaped, or spiral. A prokaryotic cell structure is as follows:

1. **Capsule**– It is an outer protective covering found in the bacterial cells, in addition to the cell wall. It helps in moisture retention, protects the cell when engulfed, and helps in the attachment of cells to nutrients and surfaces.
2. **Cell Wall**– It is the outermost layer of the cell which gives shape to the cell.
3. **Cytoplasm**– The cytoplasm is mainly composed of enzymes, salts, cell organelles and is a gel-like component.
4. **Cell Membrane**– This layer surrounds the cytoplasm and regulates the entry and exit of substances in the cells.

5. **Pili**– These are hair-like outgrowths that attach to the surface of other bacterial cells.
6. **Flagella**– These are long structures in the form of a whip, that help in the locomotion of a cell.
7. **Ribosomes**– These are involved in protein synthesis.
8. **Plasmids**– Plasmids are non-chromosomal DNA structures. These are not involved in reproduction.
9. **Nucleoid Region**– It is the region in the cytoplasm where the genetic material is present.

A prokaryotic cell lacks certain organelles like mitochondria, endoplasmic reticulum, and Golgi bodies.

#### Prokaryotic Cell Diagram

The prokaryotic cell diagram given below represents a bacterial cell. It depicts the absence of a true nucleus and the presence of a flagellum that differentiates it from a eukaryotic cell.

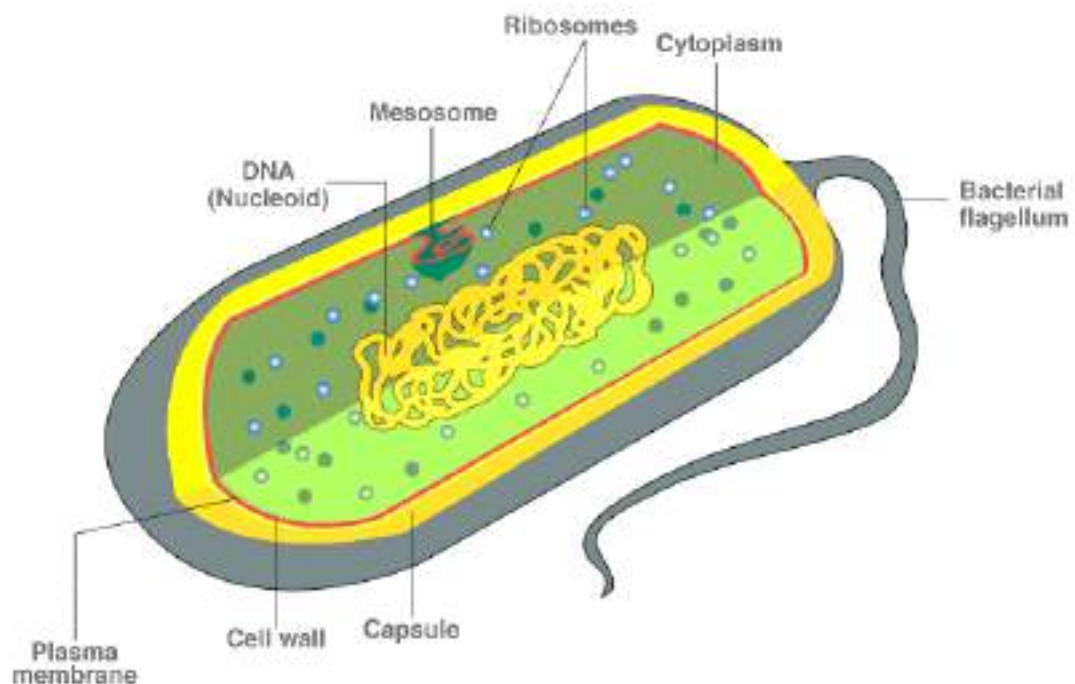

Prokaryotic Cell Diagram illustrates the absence of a true nucleus

#### Components of Prokaryotic Cells

The prokaryotic cells have four main components:

**Plasma Membrane**- It is an outer protective covering of phospholipid molecules which separates the cell from the surrounding environment.



**Cytoplasm-** It is a jelly-like substance present inside the cell. All the cell organelles are suspended in it.

**DNA-** It is the genetic material of the cell. All the prokaryotes possess a circular DNA. It directs what proteins the cell creates. It also regulates the actions of the cell.

**Ribosomes-** Protein synthesis occurs here.

Some prokaryotic cells possess cilia and flagella which helps in locomotion.

## Photosynthesis in Bacteria

### Introduction

Photosynthetic bacteria have been around for longer than the Earth's atmosphere could sustain human life. It was only recently though that scientists began to unravel the mystery of how these micro-organisms execute the mechanisms of photosynthesis.

While scientists still have not been able to put all the pieces of the photosynthetic bacteria puzzle in the right places, they are actively studying them and are gaining valuable knowledge about the way they photosynthesize and how they have evolved. In fact, they believe that these micro-organisms may have had a huge impact on why the world evolved the way it did, and may show potential for life in places deemed uninhabitable, including extreme climates like Antarctica and even other planets.

### What are photosynthetic bacteria?

Much like the name suggests, these micro-organisms are special types of bacteria that contain light absorbing pigments and reaction centers which make them capable of converting light energy into chemical energy.

Cyanobacteria contain chlorophyll while other forms of bacteria contain bacteriochlorophyll. Although bacteriochlorophyll resembles chlorophyll, it absorbs light of a longer wavelength than chlorophyll. Bacteriochlorophyll a is the most common form of bacteriochlorophyll but other forms include b, c, d, e, f and g.

Bacteria that contain bacteriochlorophyll do not use water as an electron donor and therefore do not produce oxygen. This is known as anoxygenic photosynthesis.

Cyanobacteria perform photosynthesis using water as an electron donor in a similar manner to plants. This results in the production of oxygen and is known as oxygenic photosynthesis.

### Classification of Photosynthetic Bacteria

**Oxygenic photosynthetic bacteria** perform photosynthesis in a similar manner to plants. They contain light-harvesting pigments, absorb carbon dioxide, and release oxygen. **Cyanobacteria or Cyanophyta** are the only form of oxygenic photosynthetic bacteria known to date. There are, however, several species of Cyanobacteria. They are often blue-green in color and are thought to have contributed to the biodiversity on Earth by helping to convert the Earth's early oxygen-deficient atmosphere to an oxygen-rich

environment. This transformation meant that most anaerobic organisms that thrived in the absence of oxygen eventually became extinct and new organisms that were dependent on oxygen began to emerge.

Cyanobacteria are mostly found in water but can survive on land, in rocks, and even in animal shells (or fur), and in coral. They are also known to be endosymbiont, which means they can live within the cells or body of another organism in a mutually beneficial way. Cyanobacteria also tend to live in extreme weather conditions, such as Antarctica, and are interesting to scientists because they may indicate a chance for life on other planets such as Mars.

**Anoxygenic photosynthetic bacteria** consume carbon dioxide but do not release oxygen. These include Green and Purple bacteria as well as Filamentous Anoxygenic Phototrophs (FAPs), Phototrophic Acidobacteria, and Phototrophic Heliobacteria. Let's look at the differences between these types of bacteria a little more closely.

**Purple bacteria** can be divided into two main types – the Chromatiaceae, which produce sulfur particles inside their cells, and the Ectothiorhodospiraceae, which produce sulphur particles outside their cells. They cannot photosynthesize in places that have an abundance of oxygen, so they are typically found in either stagnant water or hot sulfuric springs.

Instead of using water to photosynthesize, like plants and cyanobacteria, purple sulfur bacteria use hydrogen sulfide as their reducing agent, which is why they give off sulfur rather than oxygen.

Purple bacteria are probably the most widely studied photosynthetic bacteria, being used for all sorts of scientific endeavors including theories on possible microbiological life on other planets.

**Purple non-sulfur bacteria** do not release sulfur because instead of using hydrogen sulfide as its reducing agent, they use hydrogen. While these bacteria can tolerate small amounts of sulfur, they tolerate much less than purple or green sulfur bacteria, and too much hydrogen sulfide is toxic to them.

**Green sulfur bacteria** generally do not move (non-motile), and can come in multiple shapes such as spheres, rods, and spirals. These bacteria have been found deep in the ocean near a black smoker in Mexico, where they survived off the light of a thermal vent. They have also been found underwater near Indonesia. These bacteria can survive in extreme conditions, like the other types of photosynthetic bacteria, suggesting an evolutionary potential for life in places otherwise thought uninhabitable.

**Phototrophic Acidobacteria** are found in a lot of soils and are fairly diverse. Some are acidophilic meaning they thrive under very acidic conditions. However, not much is known about this grouping of bacteria, because they are fairly new, the first being found in 1991.

**Phototrophic Heliobacteria** are also found in soils, especially water-saturated fields, like rice paddies. They use a particular type of bacteriochlorophyll, labelled g, which differentiates

them from other types of photosynthetic bacteria. They are photoheterotroph, which means that they cannot use carbon dioxide as their primary source of carbon.

**Green and red filamentous anoxygenic phototrophs (FAPs)** were previously called green non-sulfur bacteria, until it was discovered that they could also use sulfur components to work through their processes. This type of bacteria uses filaments to move around. The color depends on the type of bacteriochlorophyll the particular organism uses. What is also unique about this form of bacteria is that it can either be photoautotrophic, meaning they create their own energy through the sun's energy; chemoorganotrophic, which requires a source of carbon; or photoheterotrophic, which, as explained above, means they don't use carbon dioxide for their carbon source.

## CYCLES

### What is Calvin Cycle?

Calvin cycle is also known as C<sub>3</sub> cycle or light-independent or dark reaction of photosynthesis. However, it is most active during the day when NADPH and ATP are abundant. To build organic molecules, the plant cells use raw materials provided by the light reactions:

- 1. Energy:** ATP provided by cyclic and noncyclic photophosphorylation, which drives the endergonic reactions.
- 2. Reducing power:** NADPH provided by photosystem I is the source of hydrogen and the energetic electrons required to bind them to carbon atoms. Much of the light energy captured during photosynthesis ends up in the energy-rich C—H bonds of sugars.

Plants store light energy in the form of carbohydrates, primarily starch and sucrose. The carbon and oxygen required for this process are obtained from CO<sub>2</sub>, and the energy for carbon fixation is derived from the ATP and NADPH produced during the photosynthesis process.

The conversion of CO<sub>2</sub> to carbohydrate is called Calvin Cycle or C<sub>3</sub> cycle and is named after Melvin Calvin who discovered it. The plants that undergo Calvin cycle for carbon fixation are known as C<sub>3</sub> plants.

Calvin Cycle requires the enzyme ribulose-1,5-bisphosphate carboxylase/oxygenase commonly called rubisco. It generates the triose phosphates 3-phosphoglycerate (3-PGA), glyceraldehyde-3P (GAP) and dihydroxyacetone phosphate (DHAP), all of which are used to synthesize the hexose phosphates fructose-1,6-bisphosphate and fructose 6-phosphate.

### C<sub>3</sub> Cycle Diagram

The Calvin cycle diagram below shows the different stages of Calvin Cycle or C<sub>3</sub> cycle that includes carbon fixation, reduction and regeneration.

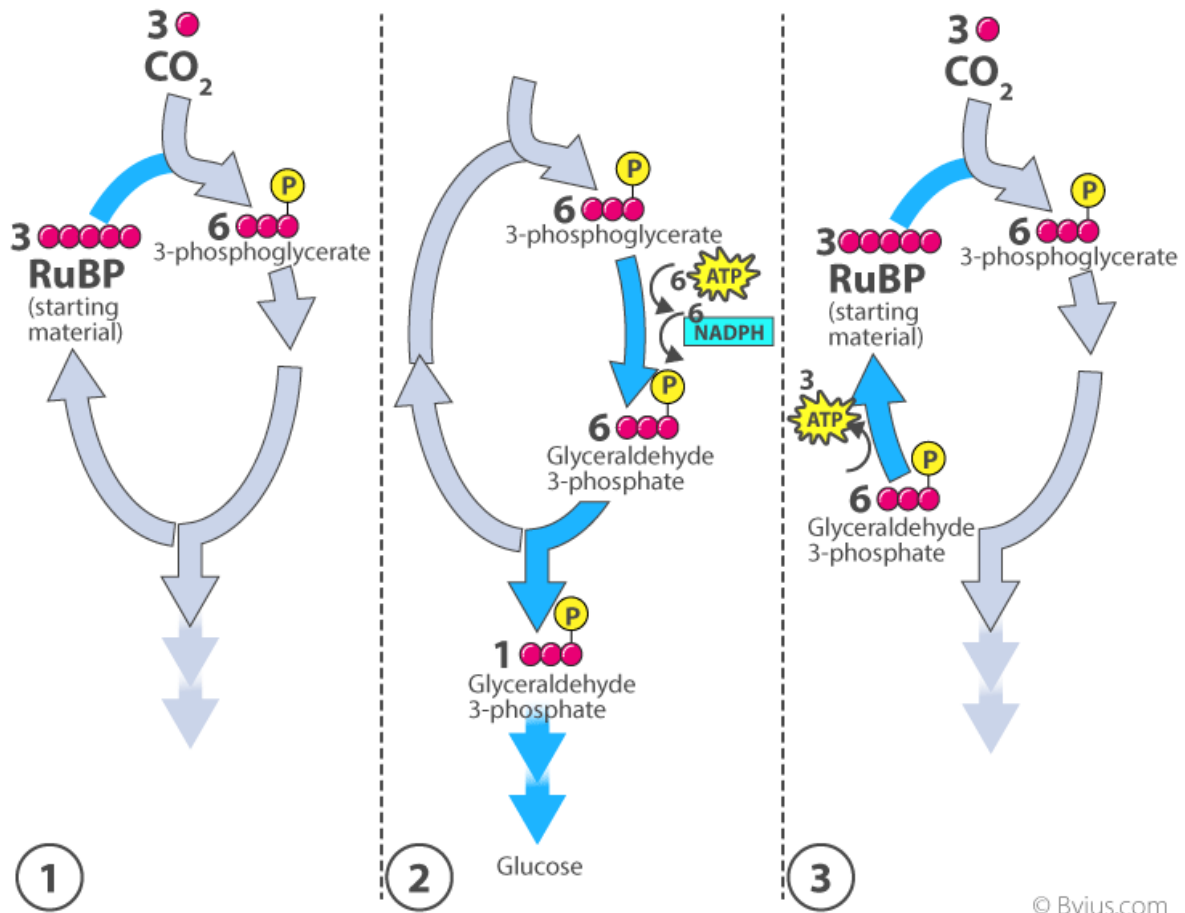

### C<sub>3</sub> Cycle Diagram

### Stages of C<sub>3</sub> Cycle

Calvin cycle or C<sub>3</sub> cycle can be divided into three main stages:

#### Carbon fixation

The key step in Calvin cycle is the event that reduces CO<sub>2</sub> and attaches it to a very special organic molecule. Photosynthetic cells produce this molecule by reassembling the bonds of two intermediates in glycolysis; fructose 6-phosphate, and glyceraldehyde 3-phosphate, to form the energy-rich five-carbon sugar, ribulose 1,5-bisphosphate (RuBP), and a four-carbon sugar.

CO<sub>2</sub> binds to RuBP in the key process called carbon fixation, forming two-three carbon molecules of phosphoglycerate. The enzymes that carry out this reaction are ribulose bisphosphate carboxylase/oxygenase, which is very large with a four-subunit enzyme present in the chloroplast stroma. This enzyme works very sluggishly, processing only about three molecules of RuBP per second (a typical enzyme process about 1000 substrate molecules per second). This is mainly because of the enzymes works slowly, and many molecules of Rubisco are needed. In a typical leaf, over 50% of all the protein is rubisco. It is thought to be the most abundant protein on earth.

### Reduction

It is the second stage of Calvin cycle. The 3-PGA molecules created through carbon fixation that are converted into molecules of simple sugar – glyceraldehyde-3 phosphate (G3P).

This stage obtains energy from ATP and NADPH formed during the light-dependent reactions of photosynthesis. In this way, Calvin cycle becomes a pathway in which plants convert sunlight energy into long-term storage molecules, such as sugars. The energy from the ATP and NADPH is transferred to the sugars.

This step is known as reduction since electrons are transferred to 3-PGA molecules to form glyceraldehyde-3 phosphate. The reduction is the process of donating one electron.

### Regeneration

It is the third stage of Calvin cycle and is a complex process which requires ATP. In this stage, some of the G3P molecules are used to produce glucose, while others are recycled to regenerate the RuBP acceptor.

### Products of C3 Cycle

- One molecule of carbon is fixed in each turn of calvin cycle.
- One molecule of glyceraldehyde-3 phosphate is created in three turns of calvin cycle.
- Three molecules of glyceraldehyde-3 phosphate combine together to form one glucose molecule.
- 3 ATP and 2 NADPH molecules are used during the reduction of 3-phosphoglyceric acid to glyceraldehyde-3 phosphate and in the regeneration of RuBP.
- 18 ATP and 12 NADPH are consumed in the production of 1 glucose molecule.

### Key Points on C3 Cycle

- C3 cycle refers to the light reaction of photosynthesis.
- It is indirectly dependent on light and the essential energy carriers are products of light-dependent reactions.
- In the first stage of calvin cycle, the light-dependent reactions are initiated and carbon dioxide is fixed.
- In the second stage of C3 cycle, ATP and NADPH reduce 3PGA to G3P. ATP and NADPH are then converted into ADP and NADP<sup>+</sup>.
- In the last stage, RuBP is regenerated. This helps in more carbon dioxide fixation

## Krebs Cycle is a part of Cellular Respiration

Cellular respiration is a catabolic reaction taking place in the cells. It is a biochemical process by which nutrients are broken down to release energy, which gets stored in the form of ATP and waste products are released. In aerobic respiration, oxygen is required.

Cellular respiration is a four-stage process. In the process, glucose is oxidised to carbon dioxide and oxygen is reduced to water. The energy released in the process is stored in the form of ATPs. 36 to 38 ATPs are formed from each glucose molecule.

The four stages are:

1.
  1. **Glycolysis:** Partial oxidation of a glucose molecule to form 2 molecules of pyruvate. This process takes place in the cytosol.
  2. **Formation of Acetyl CoA:** Pyruvate formed in glycolysis enters the mitochondrial matrix. It undergoes oxidative decarboxylation to form two molecules of Acetyl CoA. The reaction is catalysed by pyruvate dehydrogenase enzyme.

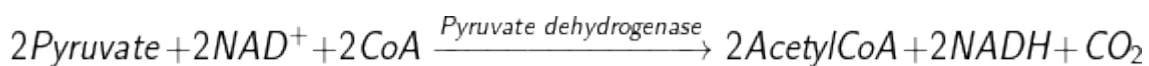

1. **Krebs cycle (TCA or Citric Acid Cycle):** It is the common pathway for complete oxidation of carbohydrates, proteins and lipids as they are metabolised to acetyl coenzyme A or other intermediates of the cycle. The Acetyl CoA produced enters the Tricarboxylic acid cycle or Citric acid cycle. Glucose is fully oxidised in this process. The acetyl CoA combines with oxaloacetate (4C) to form citrate (6C). In this process, 2 molecules of CO<sub>2</sub> are released and oxaloacetate is recycled. Energy is stored in ATP and other high energy compounds like NADH and FADH<sub>2</sub>.
2. **Electron Transport System and Oxidative Phosphorylation:** ATP is generated when electrons are transferred from the energy-rich molecules like NADH and FADH<sub>2</sub>, produced in glycolysis, citric acid cycle and fatty acid oxidation to molecular O<sub>2</sub> by a series of electron carriers. O<sub>2</sub> is reduced to H<sub>2</sub>O. It takes place in the inner membrane of mitochondria.

## Krebs Cycle Steps

It is an eight-step process. Krebs cycle takes place in the matrix of mitochondria under aerobic condition.

**Step 1:** First step is the condensation of acetyl CoA with oxaloacetate (4C) to form citrate (6C), coenzyme A is released. The reaction is catalysed by *citrate synthase*.

**Step 2:** Citrate is converted to its isomer, isocitrate. The enzyme *aconitase* catalyses this reaction.

**Step 3:** Isocitrate undergoes dehydrogenation and decarboxylation to form  $\alpha$ -ketoglutarate (5C). A molecular of  $\text{CO}_2$  is released. *Isocitrate dehydrogenase* catalyses the reaction. It is an  $\text{NAD}^+$  dependent enzyme.  $\text{NAD}^+$  is converted to  $\text{NADH}$ .

**Step 4:**  $\alpha$ -ketoglutarate (5C) undergoes oxidative decarboxylation to form succinyl CoA (4C). The reaction is catalyzed by  *$\alpha$ -ketoglutarate dehydrogenase* enzyme complex. One molecule of  $\text{CO}_2$  is released and  $\text{NAD}^+$  is converted to  $\text{NADH}$ .

**Step 5:** Succinyl CoA is converted to succinate by the enzyme *succinyl CoA synthetase*. This is coupled with substrate-level phosphorylation of GDP to form GTP. GTP transfers its phosphate to ADP forming ATP.

**Step 6:** Succinate is oxidised to fumarate by the enzyme *succinate dehydrogenase*. In the process,  $\text{FAD}$  is converted to  $\text{FADH}_2$ .

**Step 7:** Fumarate gets converted to malate by addition of one  $\text{H}_2\text{O}$ . The enzyme catalysing this reaction is *fumarase*.

**Step 8:** Malate is dehydrogenated to form oxaloacetate, which combines with another molecule of acetyl CoA and starts the new cycle. Hydrogens removed get transferred to  $\text{NAD}^+$  forming  $\text{NADH}$ . *Malate dehydrogenase* catalyses the reaction.

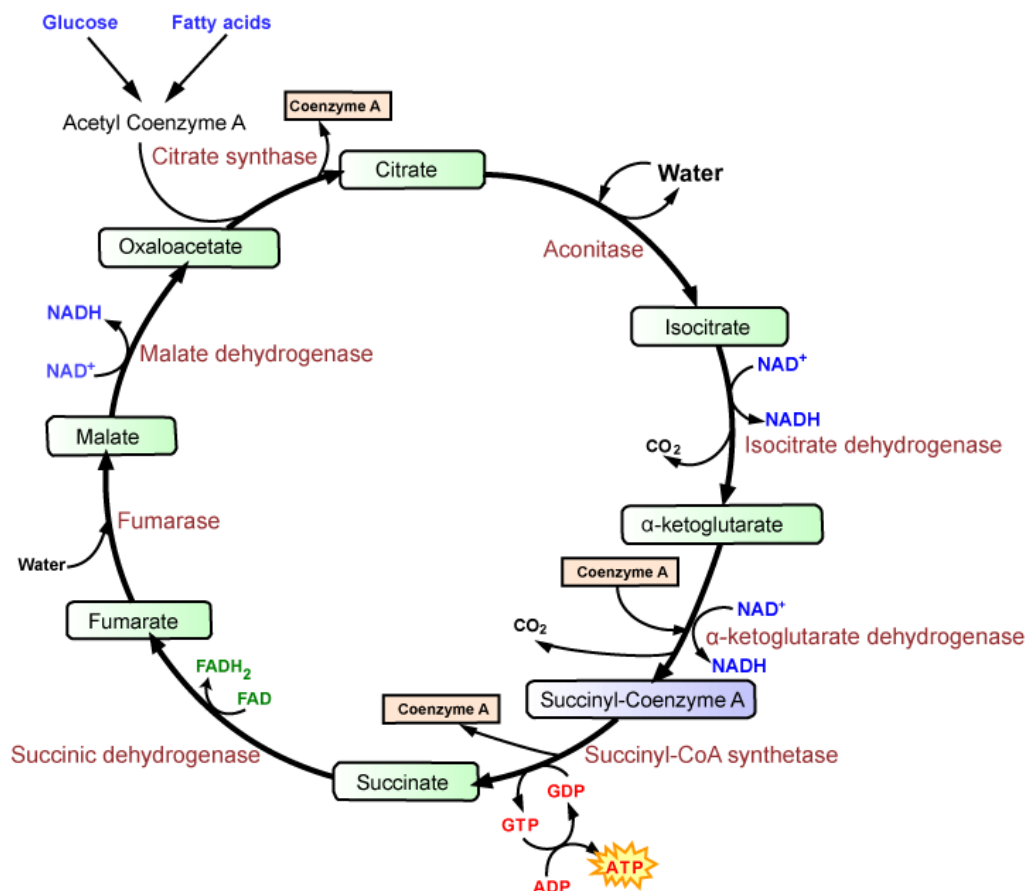

## Krebs Cycle Summary

**Location:** Krebs cycle occurs in the mitochondrial matrix

**Krebs cycle reactants:** Acetyl CoA, which is produced from the end product of glycolysis, i.e. pyruvate and it condenses with 4 carbon oxaloacetate, which is generated back in the Krebs cycle

### Krebs cycle products

Each citric acid cycle forms the following products:

- 2 molecules of CO<sub>2</sub> are released. Removal of CO<sub>2</sub> or decarboxylation of citric acid takes place at two places:
  1. In the conversion of isocitrate (6C) to  $\alpha$ -ketoglutarate (5C)
  2. In the conversion of  $\alpha$ -ketoglutarate (5C) to succinyl CoA (4C)
- 1 ATP is produced in the conversion of succinyl CoA to succinate
- 3 NAD<sup>+</sup> are reduced to NADH and 1 FAD<sup>+</sup> is converted to FADH<sub>2</sub> in the following reactions:
  1. Isocitrate to  $\alpha$ -ketoglutarate → NADH
  2.  $\alpha$ -ketoglutarate to succinyl CoA → NADH
  3. Succinate to fumarate → FADH<sub>2</sub>
  4. Malate to Oxaloacetate → NADH

Note that 2 molecules of Acetyl CoA are produced from oxidative decarboxylation of 2 pyruvates so two cycles are required per glucose molecule.

To summarize, for complete oxidation of a glucose molecule, Krebs cycle yields 4 CO<sub>2</sub>, 6NADH, 2 FADH<sub>2</sub> and 2 ATPs.

Each molecule of NADH can form 2-3 ATPs and each FADH<sub>2</sub> gives 2 ATPs on oxidation in the electron transport chain.

### Krebs cycle equation

To Sum up

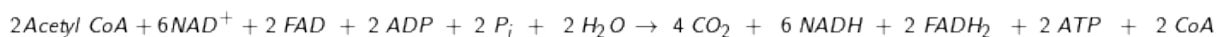

### Significance of Krebs Cycle

- Krebs cycle or Citric acid cycle is the final pathway of oxidation of glucose, fats and amino acids
- Many animals are dependent on nutrients other than glucose as an energy source



- Amino acids (metabolic product of proteins) are deaminated and get converted to pyruvate and other intermediates of the Krebs cycle. They enter the cycle and get metabolised e.g. alanine is converted to pyruvate, glutamate to  $\alpha$ -ketoglutarate, aspartate to oxaloacetate on deamination
- Fatty acids undergo  $\beta$ -oxidation to form acetyl CoA, which enters the Krebs cycle
- It is the major source of ATP production in the cells. A large amount of energy is produced after complete oxidation of nutrients
- It plays an important role in gluconeogenesis and lipogenesis and interconversion of amino acids
- Many intermediate compounds are used in the synthesis of amino acids, nucleotides, cytochromes and chlorophylls, etc.
- Vitamins play an important role in the citric acid cycle. Riboflavin, niacin, thiamin and pantothenic acid as a part of various enzymes cofactors (FAD, NAD) and coenzyme A
- Regulation of Krebs cycle depends on the supply of  $\text{NAD}^+$  and utilization of ATP in physical and chemical work
- The genetic defects of the Krebs cycle enzymes are associated with neural damage
- As most of the processes occur in the liver to a significant extent, damage to liver cells has a lot of repercussions. Hyperammonemia occurs in liver diseases and leads to convulsions and coma. This is due to reduced ATP generation as a result of the withdrawal of  $\alpha$ -ketoglutarate and formation of glutamate, which forms glutamine